





SOLLEVATORE OLEOPNEUMATICO AIR HYDRAULIC JACK

Mod.

	YAK 312	YAK 510
	•	•
	•	•
	•	•

Sollevatori Oleopneumatici con rientro automatico dei pistoni. Studiati appositamente per il sollevamento degli autobus e di quei mezzi i cui assali risultano essere molto bassi.

Air-hydraulic jacks with pistons moving back automatically. Specifically designed for lifting buses and all vehicles with low profile axles.

ACCESSORI DI SERIE - STANDARD ACCESSORIES





YAK 312

YAK 510

YAK 312

YAK 510

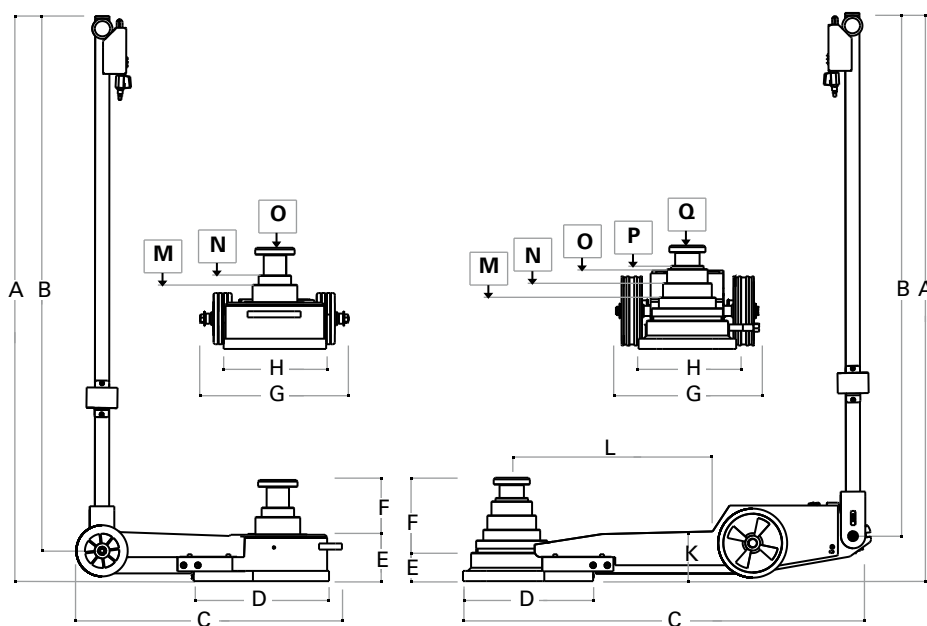

	YAK 312	YAK 510
Portata Capacity	60-30-15 t <i>66-33-17 ton</i>	44-32-22-14-8 t <i>49-35-24-15-9 ton</i>
Peso netto Net weight	50 kg <i>110 lb</i>	63 kg <i>139 lb</i>
Pressione di alimentazione Working air pressure	8-10 bar <i>116-145 psi</i>	8-10 bar <i>116-145 psi</i>
Consumo d'aria Air waste	600 nl/min	600 nl/min
A	1385 mm <i>54.53 in</i>	1385 mm <i>54.53 in</i>
B	1315 mm <i>51.57 in</i>	1315 mm <i>51.57 in</i>
C	660 mm <i>25.98 in</i>	1000 mm <i>39.37 in</i>
D	330 mm <i>12.99 in</i>	320 mm <i>12.60 in</i>
E	120 mm <i>4.74 in</i>	100 mm <i>3.94 in</i>
F	135 mm <i>5.31 in</i>	160 mm <i>6.3 in</i>
G	300 mm <i>11.81 in</i>	350 mm <i>13.78 in</i>
H	250 mm <i>9.84 in</i>	240 mm <i>9.45 in</i>
K		120 mm <i>4.72 in</i>
L		500 mm <i>19.69 in</i>
M	60 t <i>66 ton</i>	44 t <i>49 ton</i>
N	30 t <i>33 ton</i>	32 t <i>35 ton</i>
O	15 t <i>17 ton</i>	22 t <i>24 ton</i>
P		14 t <i>15 ton</i>
Q		8 t <i>9 ton</i>