

Instruction Manual

Compac wheel dolly, model WD Mobile.

Congratulations:

Congratulations on your new WD Mobile, which we are sure will live up to your expectations. Please read these operating instructions carefully to get the most out of your WD Mobile for years to come.

Warranty:

Compac offers a 3 year warranty from the date of purchase. The warranty is only valid if all of the measures specified in these operating instructions are observed. The warranty covers any defects in the workmanship and materials.

Wearing parts are not covered by the 3 year warranty. For the terms of the warranty, see www.compac.dk.

In case of problems, contact the Compac dealer you purchased the product from.

Liability:

These operating instructions must be stored together with the WD Mobile. They must always be available to the user for perusal. The manufacturer of the WD Mobile shall not be liable for any lack of familiarity with the content of the operating instructions. If the user does not understand Danish, the owner must ensure that an explanation is provided in the user's native language, so the machine may be used in a safe and responsible manner.

Use:

WD Mobile is a mobile lifting cart for carrying large wheels with a max. wheel size of 22.5" and outer diameter of up to 1120 mm.

250 kg capacity. Remove the wheel by placing the WD Mobile under the wheel (as illustrated ✓). Next tip WD Mobile down onto the smallest wheels, so there is contact between the wheel and the castors on the

WD Mobile. Continue to tip WD Mobile down onto the smallest wheels until the wheel is free of the axle.

It can now be carted away with the WD Mobile.

Use the unit on a plane and stable surface.

Place the wheel so that it is in contact with both castors.

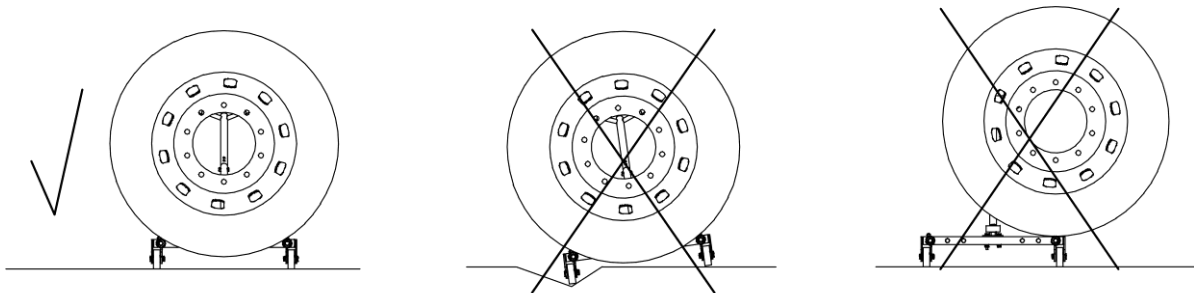

After use WD Mobile may be stored on its support foot.

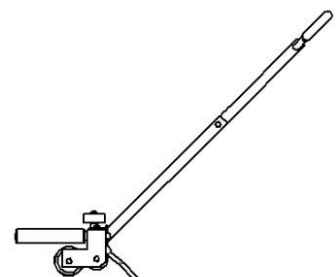

Labelling:

The unit is equipped with a CE plate.

Before assembly:

After opening the packaging, check the product for visible damage or cracks. If possible, reuse the packaging or dispose of it at a recycling centre.

Assembly:

Bag contents:

2 cotter pins	A
1 nut	B
1 screw	C
2 locknuts	D
1 washer	E

Box contents:

1 frame	F
1 push bar, upper	G
1 push bar, lower	H
1 support foot	I
2 castors	J

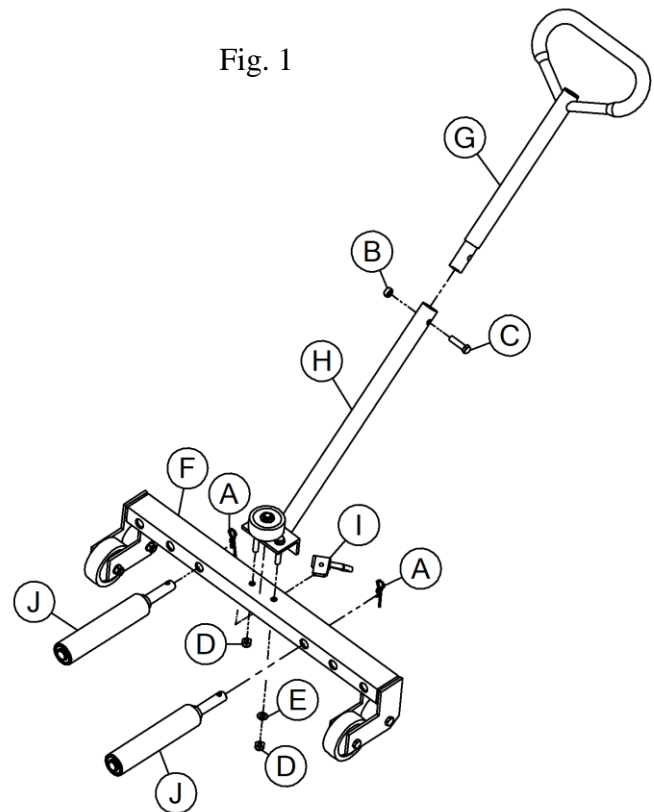

See assembly instructions.

Maintenance:

Check, clean and lubricate all mobile parts once a month. In case of rust, remove the rust from the unit and apply rust protection. Check that locknuts, nuts, bolts, castors and mandrels are intact. When replacing parts, be sure to use original parts.

Disposal:

Dispose of the unit through an authorized waste recipient.

Assembly Instructions for WD Mobile

Mounting the push bars and support foot:

Connect push bars G and H, place screw C through the hole in the push bar and screw on nut B (see photo 1 and fig. 1).

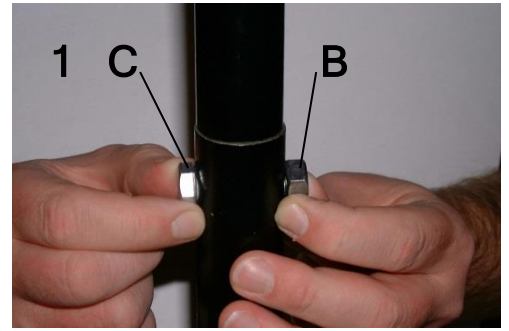

Join the full push bar to frame F (see photo 2 and fig. 1). Mount washer E and locknut D.

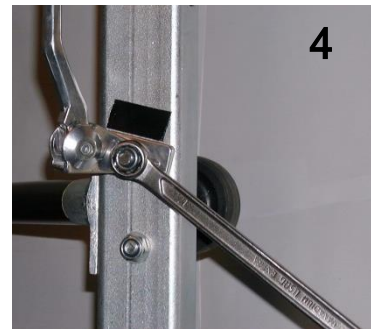
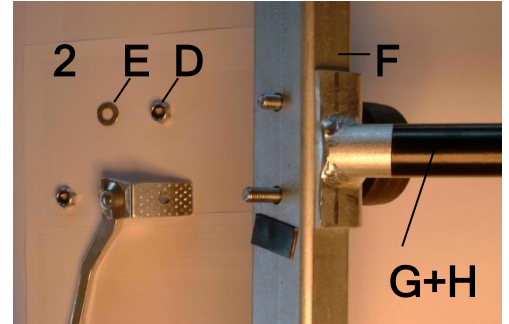

Mount support foot I, screw it on firmly and position parallel to the glued-on plate. Screw on locknut D (see photos 3+4 and fig. 1).

Mounting the castors:

Place caster J through hole in frame F, and mount cotter pin A. (see photo 5 and fig. 1).

