

VCO-K.Eco.AV6-BT.G2

INSTRUCTION MANUAL



COMPOSIZIONE

76 pagine (copertine
comprese)

74 pagine numerate

COMPOSITION

76 pages (including
cover pages)

74 numbered pages

ZUSAMMENSETZUNG

76 Seiten (inkl.
Deckblätter)

74 nummerierte Seiten

COMPOSITION

76 pages (pages de la
couverture incluses)

74 pages numérotées

COMPOSICIÓN

76 páginas (incluidas
las portadas)

74 páginas numeradas

- Per eventuali chiarimenti interpellare il più vicino rivenditore oppure rivolgersi direttamente a:
- For any further information please contact your local dealer or call:
- Im Zweifelsfall oder bei Rückfragen wenden Sie sich bitte an den nächsten Wiederverkäufer oder direkt an:
- Pour tout renseignement complémentaire s'adresser au revendeur le plus proche ou directement à:
- En caso de dudas, para eventuales aclaraciones, póngase en contacto con el distribuidor más próximo ó dirijase directamente a:

SIMBOLOGIA UTILIZZATA NEL MANUALE
SYMBOLS USED IN THE MANUAL
IN DER BETRIEBSANLEITUNG VERWENDETE ZEICHEN
SYMBOLES UTILISES DANS LA NOTICE
SIMBOLOGÍA UTILIZADA EN EL MANUAL

	SIMBOLI	SYMBOLS	ZEICHEN	SYMBOLES	SÍMBOLOS
	VIETATO!	FORBIDDEN!	VERBOTEN	INTERDIT!	PROHIBIDO!
	Obbligo! Operazioni o interventi da eseguire obbligatoriamente	Mandatory! Operations or jobs to be performed compulsorily	Vorschrift Obligatorisch auszuführende Arbeitsvorgänge oder Eingriffe	Obligation. Opérations ou interventions obligatoires	Obigación. Operaciones o intervenciones que hay que realizar obligatoriamente
	Pericolo! Prestare particolare attenzione	Hazard! Be especially careful	Gefahr! Äusserste Vorsicht ist geboden	Dager! Faire très attention	Peligro! Prestar especial atención

INDEX

0	WARNINGS	3
0.1	Preliminary safety information	3
1	INTENDED USE	4
2	STAFF TRAINING	4
2.1	General precautions	4
3	UNIT PARTS	5
3.1	Unit parts for models ART86TWS/ ART98TWSR	5
3.2	Unit parts for models ART98TWS/ ART98TWSR	6
3.3	Safety devices	7
3.4	Field of measurement and precision	7
3.5	Overall dimensions	7
3.6	Control PC	7
3.7	Sensors	8
3.7.1	Sensors ART98TWSR and front ART86TWSR	9
3.7.2	Sensors ART98TWS and front sensor ART86TWS	9
3.7.3	Rear sensor ART 86TWS and ART 86TWSR	9
3.7.4	Sensor keyboard	10
3.7.5	LED for signaling Toleranceduringadjustment	10
3.8	Wheel clamps	11
3.8.1	Wheel clamps STDA30E	11
3.8.2	Wheel clampsSTDA48E	11
3.8.3	Use of clamp STDA30E /STDA48E	12
3.8.4	Run-out for vehicles with clamp STDA30E	13
3.8.5	Wheel clampsSTDA92E	14
	14	
	14	
3.9	TURNPLATES	14
3.9.1	Turnplates STDA29E for trucks	14
4	SWITCHING THE UNIT OFF AND ON	15
4.1	Switching on	15
4.2	Switching the Machine Off	15
5	AUTOMATIC SENSOR SWITCH-OFF	17
6	LOW-BATTERY INDICATOR	17
7	PROGRAM CONFIGURATION	18
7.1	DATABANK Profile Selection	19
8	TESTING AND ADJUSTING A LIGHT VEHICLE	21
8.1	Presentation page	21
8.2	Vehicle Make and Model Selection	21
8.3	Selected Vehicle Technical Specification Displaying	24
8.4	Preliminary operations	25
8.4.1	Preliminary vehicle control operations	25
8.4.2	Preparing for run out	25
8.5	Runout	26
8.5.1	Run out raised wheels	26
8.5.2	Thrust Run-Out with Automatic Acquisition	29
8.5.1	Inclinometer-controlled Thrust Run-Out	31
8.6	Measurement Preliminary Operations	34
8.7	Detectors Alignment and Levelling	35

8.8	Steering Procedure.....	36
8.9	Vehicle Diagnosis.....	37
8.10	Adjustment Preliminary Operations	38
8.11	Rear Axle Adjustment	38
8.12	Front Axle Adjustment	39
8.12.1	<i>Front toe Adjustment at steered wheels</i>	40
8.13	Summary of Test and Adjustment data	41
8.14	Additional Functions Menu	42
8.15	Printout of Measurements taken	43
9	TESTING AND ADJUSTING A HEAVY DUTY VEHICLE	46
9.1	Adjusting a 3 axles tractor	46
9.2	Adjusting a semi-trailer with 3 back axles	52
9.3	Adjusting a 3 axles tractor - 2 steering axles.....	56
9.4	Adjusting a full trailers 2+1	61
10	DATABASE CUSTOMISATION	64
10.1	New Group Entry.....	64
10.2	New Group Deletion.....	65
10.3	New Vehicle Entry	66
10.4	Customised Vehicle Deletion	69
11	PROGRAMME AND DATABASE PROTECTION SMART CARD.....	70
11.1	DATABASE Management	70
12	DETECTORS' ERRORS	72
12.1	Data Reception/Transmission Error between Detectors and Cabin.....	72
12.2	Angle Measurement Horizontal Error	72
13	TROUBLES.....	73
14	MAINTENANCE.....	73
15	STORAGE AND SCRAPPING	74
16	MACHINE IDENTIFICATION DATA	74



The Bluetooth trademarks belong to their respective owners and are used under licence by S.r.l.

0 WARNINGS

Any damage caused by failure to observe the indications in this manual or by incorrect machine use shall exempt S.r.l. from all liability.

0.1 Preliminary safety information



Before starting up the appliance:

- Read the instructions and the entire manual before using or working on the wheel aligner. This manual is an integral part of the product. Its aim is to provide the user with instructions on how to operate the wheel aligner ART86TWS/TWSR and ART98TWS/TWSR. Look after the manual for the entire working life of the machine and keep it in a place that is known and easily accessible. Refer to it every time you have any doubts. All product operators must be able to read the manual.
- Make sure the power supply is in conformity with the specifications shown on the plate. The plate showing voltage and frequency details is positioned on the rear of the appliance. Please read this plate carefully. NEVER connect the appliance to a power source with voltage or frequency different to those shown.
- Adequately position the power cable of the wheel aligner. The machine features a 3-pin plug with integrated ground. This can only be fitted in a socket that also has a ground point. If it is not possible to fit the plug into this type of socket, contact an electrician. Do not try modifying or using the plug incorrectly.

On switching off the machine:

- Never switch off the PC inside the machine by disconnecting the plug or by means of the PC switch itself. Always follow the procedure described in para. 4.2 on page 15. Incorrect PC switch-off can "corrupt" the files inside the HARD-DISK.
- The switch-off procedure described in para. 4.2 on page 15 does not affect the measuring head recharging supports which therefore continue to be energised.

In emergency conditions and before any maintenance jobs:

- Isolate the machine from any power sources by means of the master switch and disconnect the plug from the power socket.
- Do not try servicing the machine arbitrarily because the opening and removal of the doors could expose you to hazardous voltages; maintenance jobs must only be performed by authorised after-sales service personnel.

Working environment and cleaning the machine:

- The working environment must be kept clean, dry and not exposed to atmospheric agents and must be well lit.
- Do not clean the machine with jets of water and compressed air.
- To clean the plastic panels or shelves, use a damp cloth (avoid using liquids containing solvents).

SRL shall be entitled to make any changes to the models described in this manual for technical or commercial reasons.

1 INTENDED USE

The 86TWS/TWSR and 98TWS/TWSR systems are machines for determining all the angles relating to vehicle wheel alignment.

These angles are measured by four sensors incorporating microprocessor technology and infrared data reading and transmission system [without using cable connections between the sensors].

Data transmission from the front sensors to the console is by radio frequency communication by means of modules  Bluetooth.

The machine must only be used in a field of temperature from 0° to 40°.

2 STAFF TRAINING

The machine must only be used by specially trained and authorised personnel. To ensure best machine management and that measurements can be efficiently made, operators must be properly trained in order to acquire the know-how needed to use the machine according to the instructions provided by the manufacturer. In case of any doubts relating to the use and maintenance of this machine, refer to the instruction manual; if doubts still remain, contact authorised after-sales services or the SRL technical department.

2.1 General precautions



- During machine operation and maintenance, always follow all applicable safety and accident-prevention norms.



- The machine must only be used by authorised and adequately trained personnel.



- This machine must only be used for the purpose for which it was specifically made.

SRL disclaims all liability for injuries to persons or animals and damage caused to things by incorrect machine use.



- Accessories and spare parts must only be fitted by authorised SRL personnel and original accessories and spare parts must always be used.



- The machine must only operate in places where there is no risk of explosion or fire.



- Removing or altering safety devices or the warning signals on the machine can represent a cause of serious hazard and is an infringement of European safety laws.



- Before doing any maintenance jobs on the system, disconnect the power supply. In case of doubt, do not interpret but contact the SRL after-sales service to receive instructions on how to perform operations in conditions of utmost safety.



- Avoid unauthorised persons coming near the wheel aligner during operation.

3 UNIT PARTS

3.1 Unit parts for models



MEASUREMENT CONSOLE

For all measurement-taking operations, the measurement console must be used. This features electronic components that process and manage the data from the sensors.

Power supply: 220 / 240 Vac single-phase 50/60Hz. Max power input: 500w

WHEEL CLAMPS

See para 3.8 on page 11



THE PEDAL PRESSER is a device used to block the brake pedal during measurement preparation operations. It should be used as illustrated in the instructions displayed during the program.



TURNPLATES

See para 3.8.5 on page 14



STEERING LOCK. This is a device used to keep the steering wheel in fixed position. It is used before the adjustment procedure as shown in the instructions displayed during the program.



3.3 Safety devices

The wheel aligner features a safety device (master switch) on the rear of the machine, see chap.3.1 and 3.2. The master switch disconnects power to the machine when turned clockwise.

3.4 Field of measurement and precision

Axle	Measurement	Precision	Field of measurement	Total field of measurement
Front	Toe-in	$\pm 2'$	$\pm 2^\circ$	$\pm 5^\circ$
	Semitoe-in	$\pm 1'$	$\pm 1^\circ$	$\pm 2^\circ 30'$
	Axle run-out	± 2	$\pm 2^\circ$	$\pm 5^\circ$
	Wheel camber	$\pm 2'$	$\pm 3^\circ$	$\pm 10^\circ$
	Caster angle	$\pm 5'$	$\pm 10^\circ$	$\pm 18^\circ$
	Camber angle	$\pm 5'$	$\pm 10^\circ$	$\pm 18^\circ$
Rear	Toe-in	$\pm 2'$	$\pm 2^\circ$	$\pm 5^\circ$
	Semitoe-in	$\pm 1'$	$\pm 1^\circ$	$\pm 2^\circ 30'$
	Axle run-out	$\pm 2'$	$\pm 2^\circ$	$\pm 5^\circ$
	Wheel camber	$\pm 2'$	$\pm 3^\circ$	$\pm 10^\circ$
	Push angle	$\pm 2'$	$\pm 2^\circ$	$\pm 5^\circ$

3.6 Control PC

Inside the control unit is a control PC containing the software product.
Managing PC features:

- Processore 1.6GHz;
- RAM 1Gb;
- 4 USB; 1 COM;1 LAN Ethernet 10/100Mb;
- Keyboard and PS2 mouse input; WIN 7 Embedded Standard edition in Edition
- Hard Disk ≥ 30 Gb

3.7 Sensors

The sensors of the ART86TWS/TWSR and ART98TWS/TWSR unit require no cable connections for angle measurement. The measurement units consist of infra-red data transceivers and CCD type transducers with infra-red emission focal point.

All the characteristic angles of both vehicle axles are controlled by CCD sensors (6 sensors for the ART86TWS/TWSR serie and 8 sensors for ART98TWS/TWSR serie) and infra-red transmission.

Data transmission between the infra-red sensors is effective even in critical lighting conditions.

Data transmission of the front measuring heads is VIA RADIO by means of modules  housed inside the front measuring heads and the console.

The rear sensors do not communicate directly with the console. Their data are transmitted/received through the infra-red transmission of the front sensors [see para.3.7.3 on page 9).

Power is supplied by rechargeable 6V long-life batteries; recharging of front and rear measuring heads is done through the supports for recharging the batteries of the measuring heads located on the console.

For all the sensors featuring rechargeable batteries, the power and consumption data are as follows:

	REAR HEADS ART86TWS/TWSR	ART98TWS/TWSR FRONT HEADS ART 86TWS/TWSR
Power supply	Lead battery 6V - 1.3Ah	Lead battery 6V - 3Ah
Mean autonomy with battery fully efficient and charged	About 10 hours	About 18 hours
Mean recharge time	About 10 hours	About 10 hours

3.7.1 Sensors ART98TWSR and front ART86TWSR

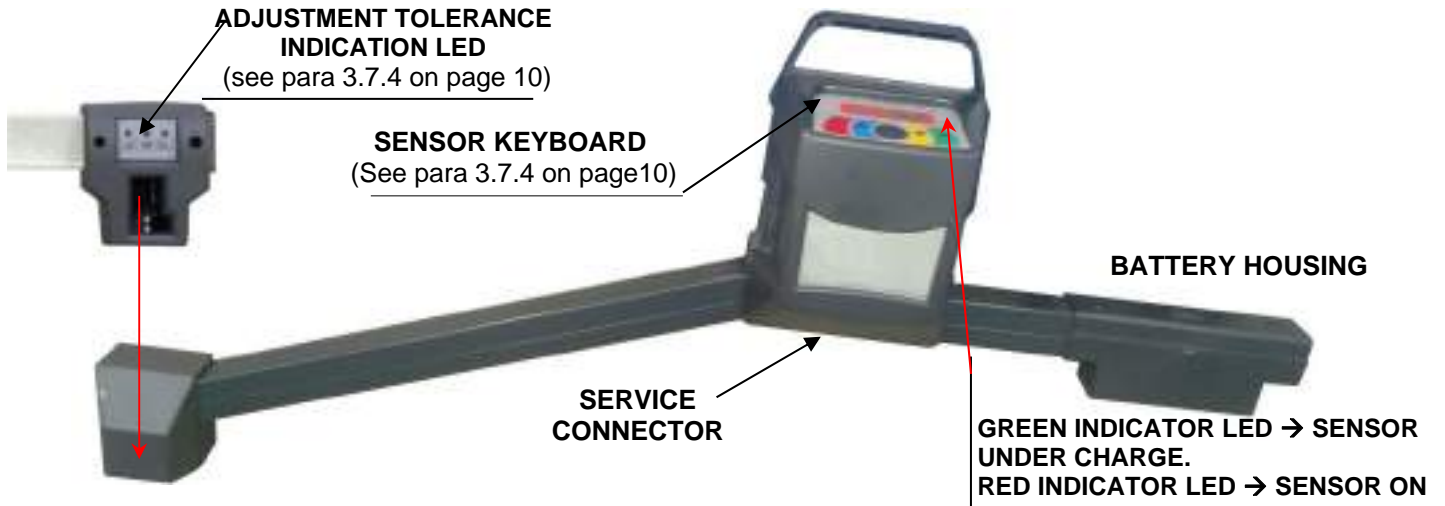

Figure2

3.7.2 Sensors ART98TWS and front sensor ART86TWS

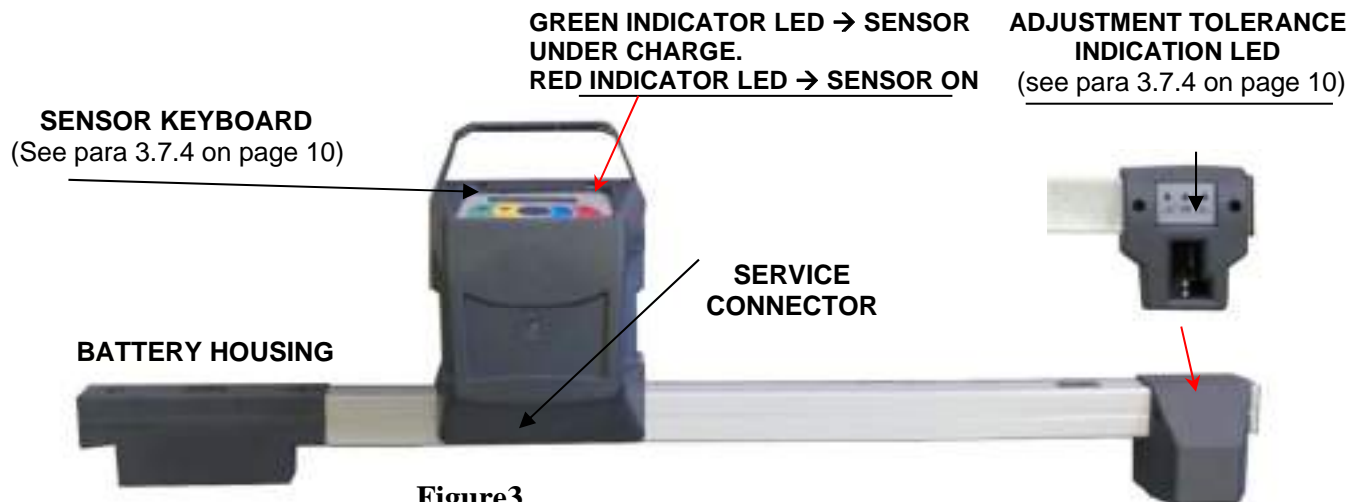

Figure3

3.7.3 Rear sensor ART 86TWS and ART 86TWSR

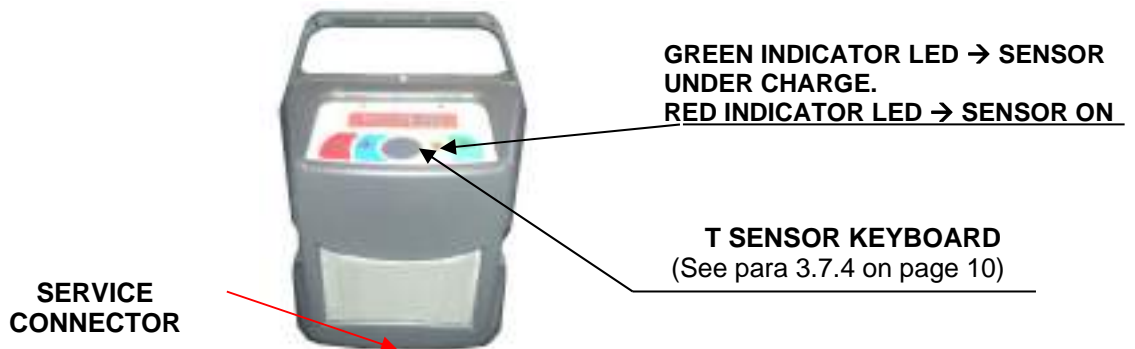





Figure4

3.7.4 Sensor keyboard



Figure5

KEY	DESCRIPTION
	Sensor switch-on key
 	When pressed together, they manually switch off the sensor

Legend of Figure5:

- A - • Green LED on: The sensor battery is under charge
- B - • Red LED on steady: Sensor on
• RED LED flashing: Sensor down (when remaining battery charge is below or same as 30%); switches off after a few minutes
- C - • Red LED on steady : Sensor is not in level
• RED LED flashing together with GREEN on: Sensor is not in level but close
C - • GREEN LED flashing: Sensor is levelled

3.7.5 LED for signaling Tolerance during adjustment

The sensor of series ART98TWS and ART86TWS are equipped with indicator for signaling of tolerance during the adjustment. See par. 3.7.1 and 3.7.2.

- GREEN LED flashing → the measurement is within tolerance, exactly at centre
- RED LED flashing together with GREEN on steady → the measurement is within tolerance
- RED LED on → the measurement is NOT within tolerance

During adjustment, to see the tolerance on the LEDs, the selection frame ("R" symbol) must be moved to the value being adjusted (see par. 8.12 on page 39).



3.8 Wheel clamps

3.8.1 Wheel clamps STDA30E

The STDA30E are self-centring wheel clamps, screw type, for 12"-24", complete with removable claws.

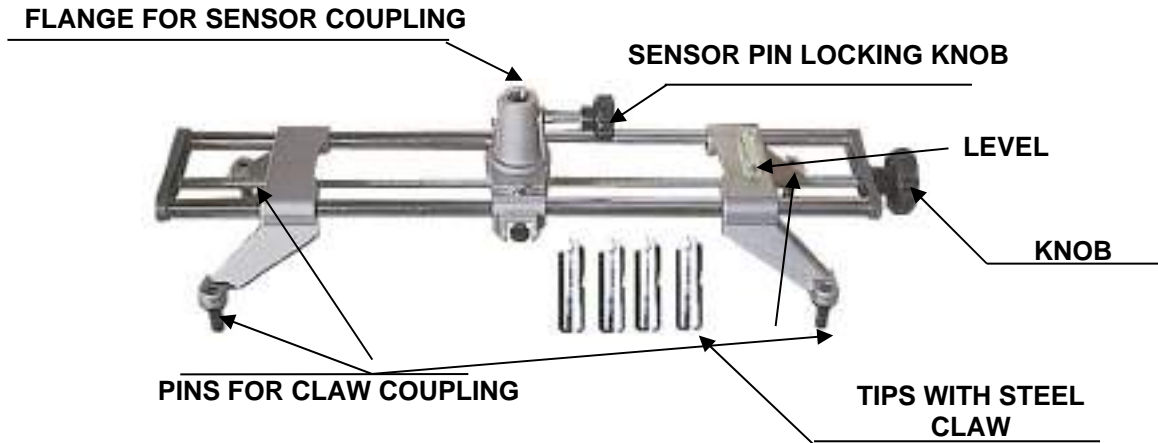

Figure6

3.8.2 Wheel clampsSTDA48E

The STDA48E wheel clamps feature 4 claws for 12" to 24" rims complete with locking units, and removable claws.

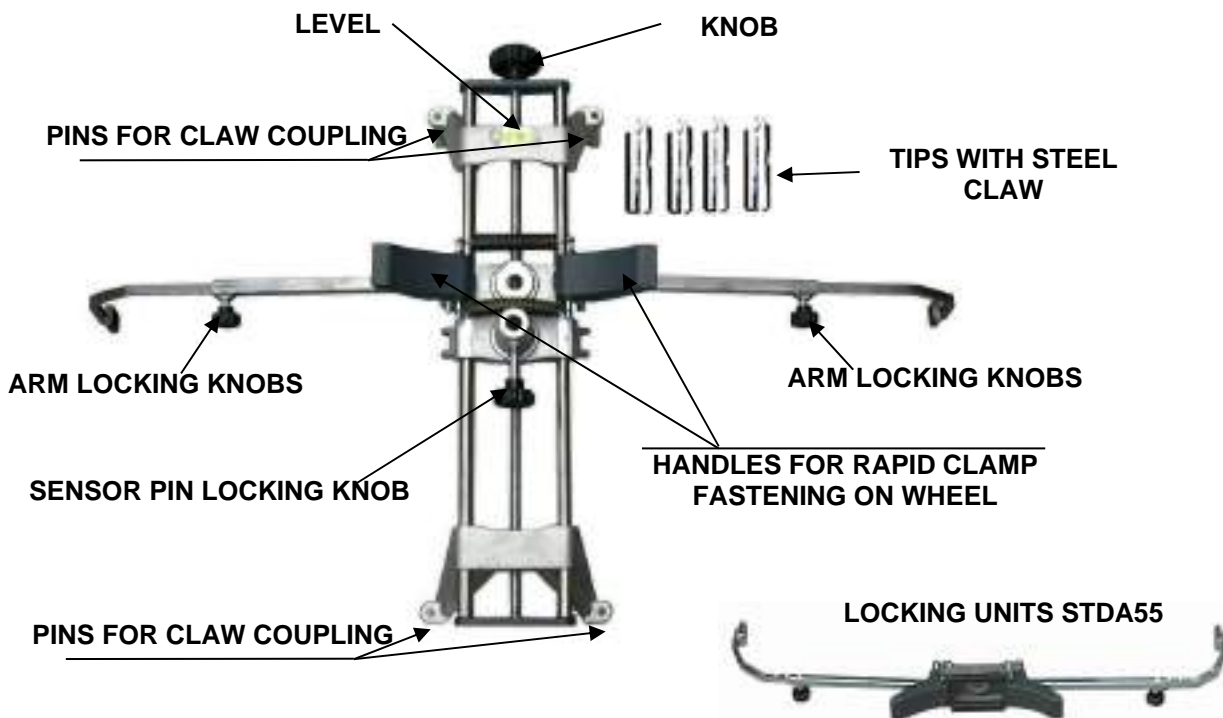

Figure7

The locking units STD A55 allows to convert the standard wheel clamps STDA30E in wheel clamps equivalent of STDA48E.

3.8.3 Use of clamp STDA30E /STDA48E

The centre crosspiece of clamps STDA30E is mobile; the clamp can therefore be raised and/or lowered by at most 180 mm in the event of an obstacle (a wide truck wheel for instance) preventing communication between the two measuring heads.

To lower the two measuring heads to the same level, the crosspiece features 3 notches, each 60 mm high.

ALWAYS LEVEL THE CLAMP BEFORE LOWERING THE CROSSPIECE (see following examples):

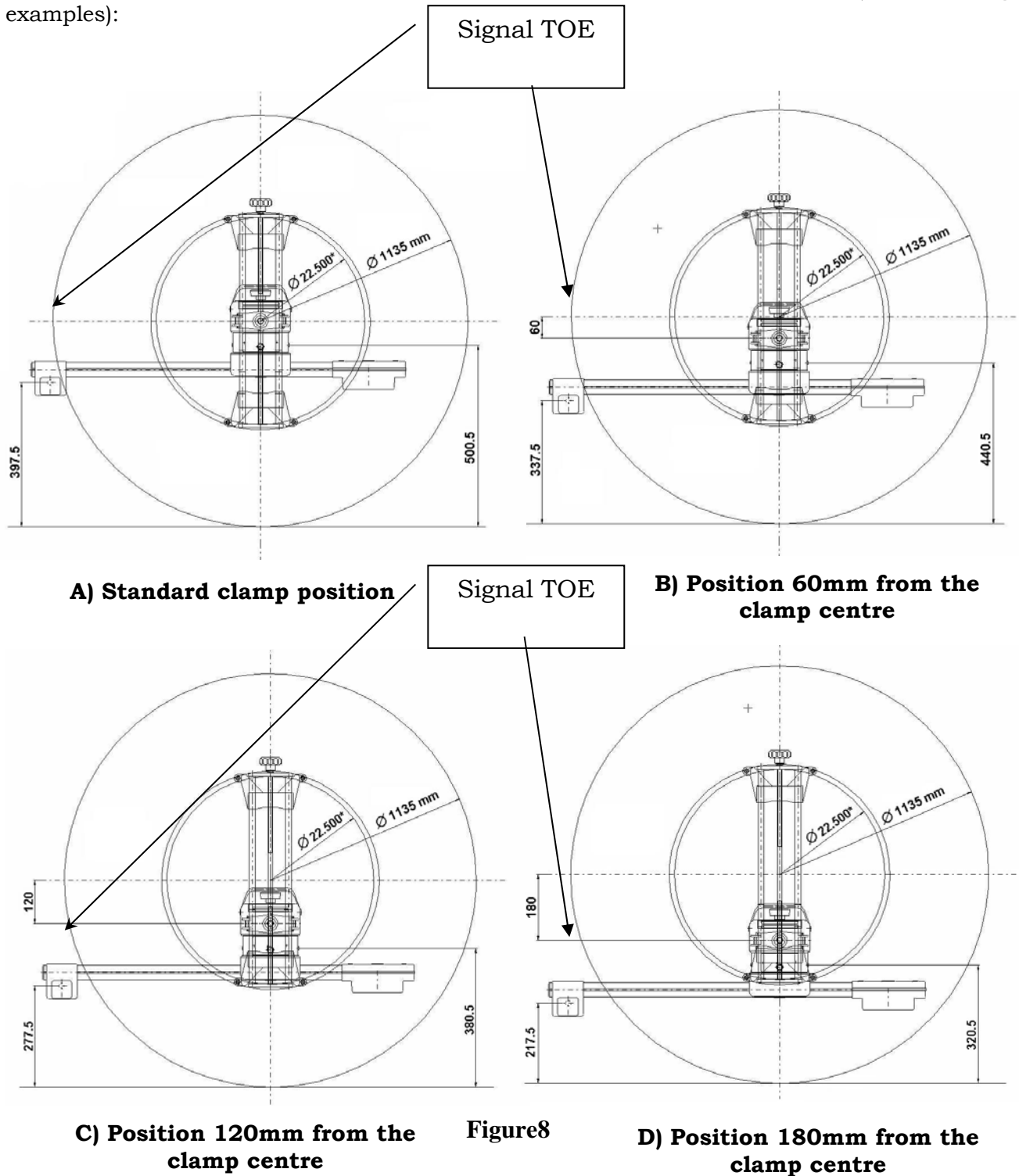

3.8.4 Run-out for vehicles with clamp STDA30E

In the event of the operator wishing to use the truck wheel clamps STDA30E on a motor-vehicle, great care must be taken as these are very long compared to the vehicle clamps. At the end of the run out procedure and when lowering the wheels, the clamp could touch the floor and consequently move or break thus affecting the result of the following tests.

During the run out procedure, the screen shows an instruction to turn the wheel, taking as reference the knob, indicated by the flashing point.

By following this procedure, the run out terminates with the clamp in vertical position (knob at top) and the clamp touches the floor when lowering the wheels.

To prevent this, take as turning reference not the knob but a point of the wheel shifted by 90° with respect to the knob (see Figure9 and Figure10), so the procedure terminates with the clamp in horizontal position.



Indication point shows on the screen for the knob position



Position the knob TOWARDS THE RIGHT

Figure9

- Turn the wheel by 180° (knob position TOWARDS THE LEFT). Press the centre key of the measuring head. Acquisition of measurements.



Indication point shows on the screen for the knob position

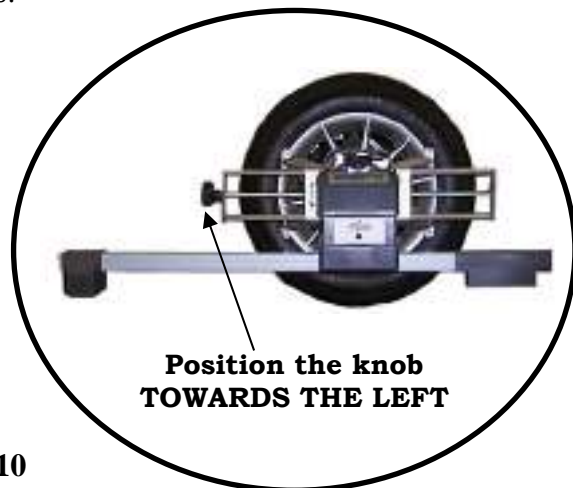

Position the knob TOWARDS THE LEFT

Figure10

The wheel clamps must all be horizontal when lowering the vehicle, once the run out procedure has terminated.

This way, during the measuring head ALIGNMENT AND LEVELLING STAGE, it will not be possible to level the clamps, but if clamps STDA30E (para. 3.8.1 on page11) are used on a vehicle it will NEVER be necessary to shift the movable crosspiece of the clamp downwards because the size of the wheels of a vehicle will never block the measuring head signal.

3.8.5 Wheel clamps STDA92E

Special NON Run-out compensation wheel clamps, by referencing the wheel center which is almost perfectly accurate, it can deliver a more accurate measurement without need to raise each wheel position to perform Run-out compensation

Each pair of clamps includes: 6 short adapters and 6 long adapters

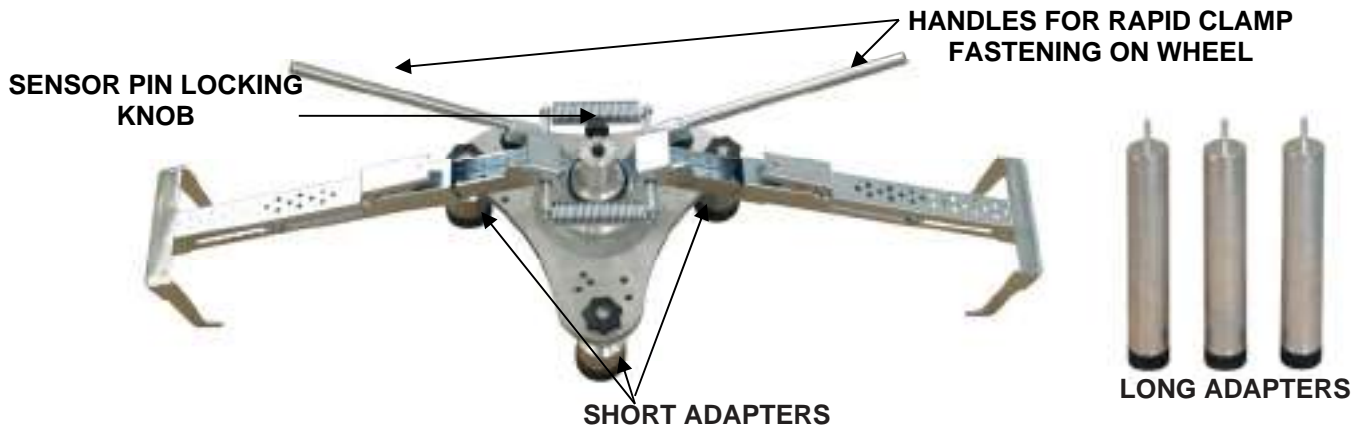

3.9 TURNPLATES

3.9.1 Turnplates STDA29E for trucks

The turnplates STDA29E have a capacity of 7000 kg.

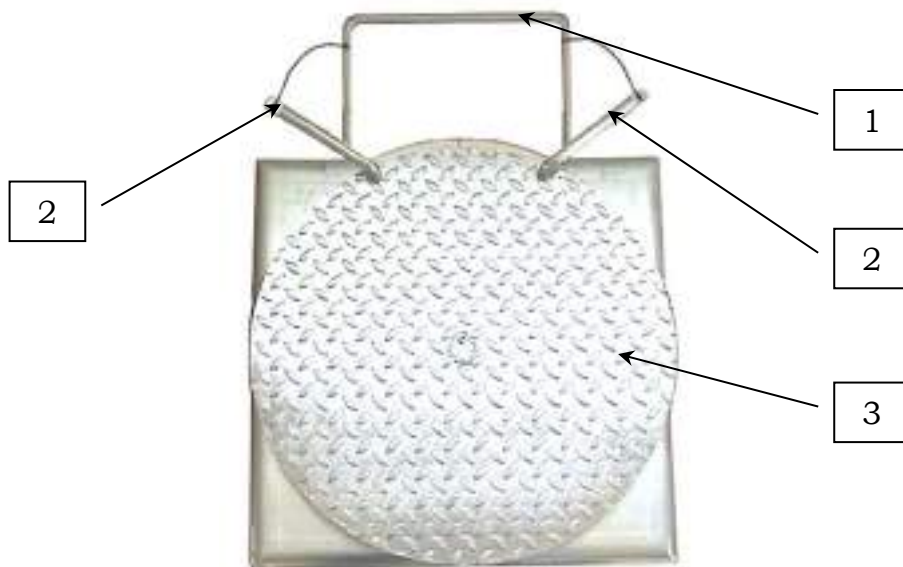

Figure11

Legend of Figure11:

- 1 - Plate handle
- 2 - Plate stop
- 3 - Upper plate with anti-drip disc

4 SWITCHING THE UNIT OFF AND ON



WARNING: Before switching the machine on, make sure that the SMART CARD for programme enabling and the database are in the special reader on PC front side.

See chap. 11.

4.1 Switching on

To switch on the machine and access the program, the specific button must be pressed situated at the rear of the console.

After PC initialisation by Windows™, the program is automatically run. The first page to appear is the program presentation page, from where all machine functions can be started (seepar. 7onpage18).



Figure12

4.2 Switching the Machine Off

From the introduction page (see par8.1on page 21) you can switch the machine off by selecting the corresponding key









	SENS. KEYBOARD	PC KEYBOARD	DESCRIPTION
			Start the procedure request for switching off the machine.



Figure13

	SENS. KEYBOARD	PC KEYBOARD	DESCRIPTION
			Cancel. Return to presentation page (par 8.1 on page 21)
			Confirm machine switch-off

Now wait for the following display page to appear.



Figure14

Switch off the machine by the main switch situated at the rear of the equipment.



IMPORTANT:

The switch-off procedure does not affect the sensor recharge supports which continue to be powered.

5 AUTOMATIC SENSOR SWITCH-OFF

The system switches the sensors off automatically whenever the presentation or screen-saver pages are displayed.

The sensors will in any case switch off after 5 approx. minutes unless they receive data (eg. the console is off).

It is in any case best to always switch off the sensors manually (see para. 3.7.4 page 10) when these are not used.

6 LOW-BATTERY INDICATOR

The system displays a low-battery indication (Figure15).

This signal is also provided on the sensor itself by means of the flashing of the red switch-on LED (see para. 3.7.4 on page 10).



Figure15

When the remaining battery charge is 30% or BELOW, the program shows the low-battery indication page (Figure15). The sensor goes off after a few minutes. Try not to reach this situation, by charging the sensors just as soon as possible.

To exit from the signal page, press F1  .

7 PROGRAM CONFIGURATION

To proceed to programme configuration, select F2  from the introduction page, as explained in par. 8.1 on page 21.

You will enter a configuration menu allowing editing the different programme characteristics according to your needs.



Figure16

Language selection: You can select your dialogue language among the many available ones.

Configuration: programme will display the screen of Figure17











You can edit system parameters, database profile, specify which parts are fitted on the machine, parts type, make a Bluetooth search to couple measuring heads with cabin.

Print Menu: Print can be customised by entering workshop data, selecting the type of desired printout, and selecting the pre-set printer (if more than one printer is connected).

Backup / Restore: In order not to run the risk to lose any vehicle and customer database data, it is recommended to create a backup copy (data saving). We recommend using a "flash disc" USB key for this process.

Lost or deleted data can be restored if the backup operation has been carried out, thanks to the restore procedure.

Additional functions: programme displays screen Figure 71, from which you can access TEST or sensor Calibration applications (reserved to skilled and authorised personnel), and the "DATABASE MANAGEMENT", see chap. 11.1

	SENS. KEYBOARD	PC KEYBOARD	DESCRIPTION
			It goes back to the introduction page. (par. 8.1 on page 21)
			It moves selection up.
			It moves selection down.
			It confirms selection.

7.1 DATABANK Profile Selection

Select the “CONFIGURATION” option on the program configuration page as explained in para. 7.1 page 19. It is possible to change the system parameters, the databank profile and specify which component parts are in the appliance and what type they are











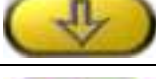

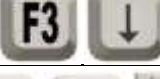



Figure17

	SENS. KEYBOARD	PC KEYBOARD	DESCRIPTION
			It goes back to the introduction page. (par. 8.1 on page 21)
			It moves selection up.
			It moves selection down.
			It confirms selection.

Select “DATABASE” option, and confirm. The following screen will be displayed:



Figure18

	SENS. KEYBOARD	PC KEYBOARD	DESCRIPTION
			It goes back to Figure 17
			It moves selection up.
			It hides/displays the different Database profiles.
			It moves selection up, displaying the following profiles.
			It confirms selection.

Page Figure 18 displays a list, with the different DATABASE profiles, including the MAKES of the vehicles circulating in the different countries and regions all over the world.

Using key F5 , you can hide and/or display any profile so as to manage Database according to your needs.



Figure 19



By selecting any group and pressing F4 , you can also customise your profile by hiding and/or displaying the available makes, with key F5 .



Figure 20

8 TESTING AND ADJUSTING A LIGHT VEHICLE

The testing and adjusting of light vehicles is possible with all models of aligners, but it is necessary special clamps for cars. It is also possible to carry out alignment with STDA30E clamps, but mounting them as illustrated in the para.3.8.4.

The ART98TWSR/ART86TWSR model (lower arms) could be used also to make testing and adjusting of light vehicles, but only having big wheels (diam. > 760mm).

8.1 Presentation page

When the machine is switched on (see para. 4page 15] the initial program display page appears, from where the different functions can be selected.



Figure21

	SENSOR KEYB.	PC KEYBOARD	DESCRIPTION
			turn-off the machine (par.4.2 page 15)
			Program configuration (para7on page18)
			Accesses client database
			Selects list with different databank profiles (para. 7.1page19)

Press F4 to continue.

8.2 Vehicle Make and Model Selection



List with different database profiles (para7.1on page19)

Figure22

Press F4  to select vehicle make and model. Programme shows the list of the makes of the selected group (see Figure24),

Or press F5  to start a search using keys (model/make/year) or the V.I.N number (Vehicle Identification Number) which is a unique serial number used by the automobile industry to identify motor vehicles. V.I.N. consists of a 17-alphanumeric digit plate usually positioned inside engine compartment. See Figure23.

Note: by pressing F5  you select the search mode: Through search keys such as Make name, model/year, or VIN (Figure23) or through a manual selection (Figure24).

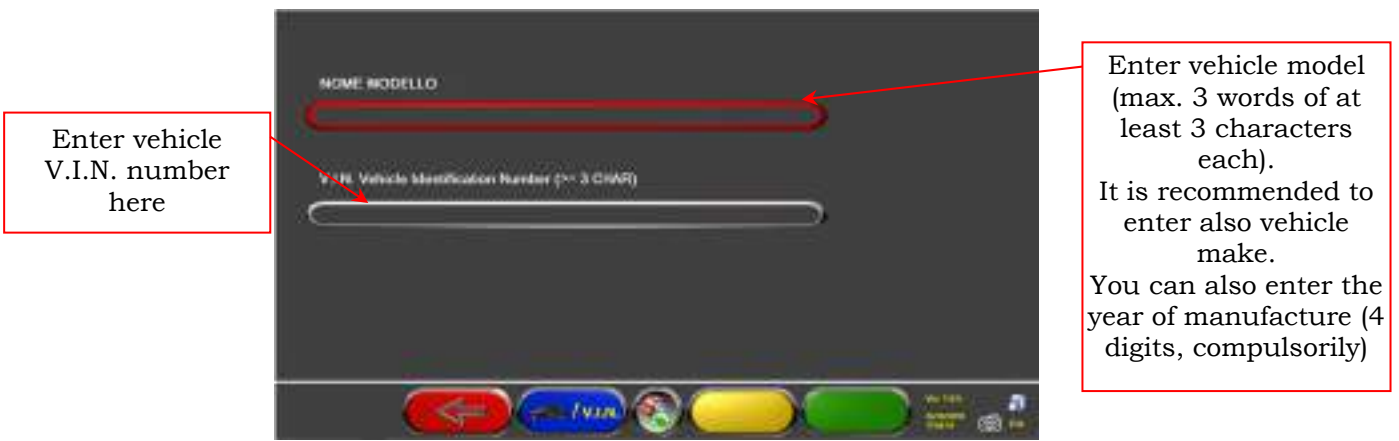



Figure23

Press  to move cursor from "model name" to "V.I.N." entering field.

Press  to continue, and display the list of all the vehicles complying with the just-entered search criteria; then select the correct vehicle and display the page of the selected vehicle technical specifications (par. 8.3)

To select vehicle make and model, press  from the introduction page (Figure21) or from the database profile page (Figure22).

The programme will display the following box:

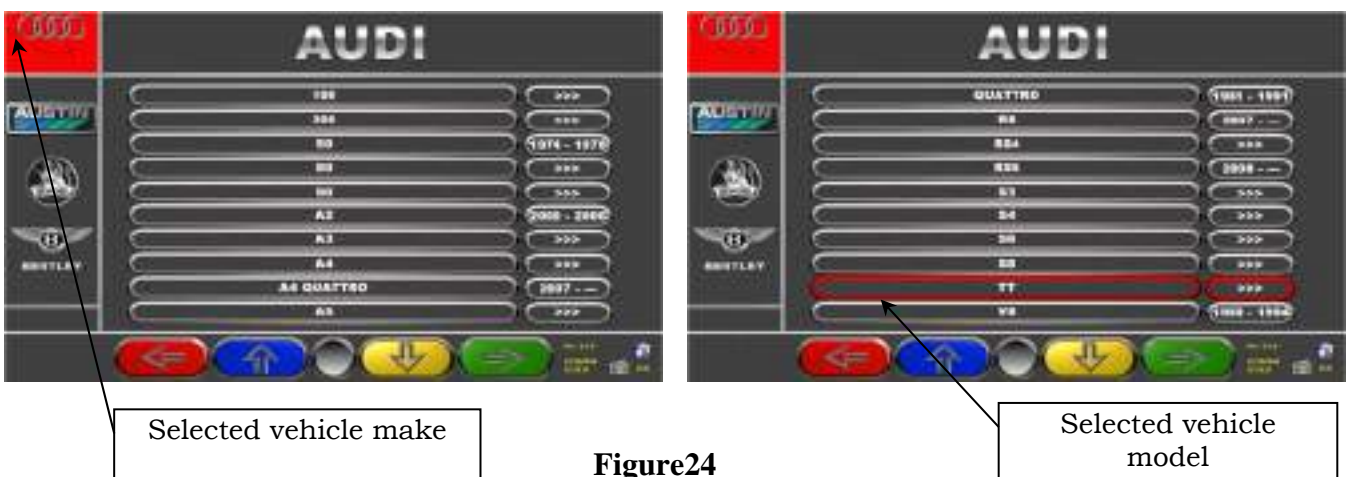

















Figure24

Make and model of the vehicle you are going to work on shall be compulsorily selected

	SENS. KEYBOARD	PC KEYBOARD	DESCRIPTION
			It goes back to the introduction page (par. 8.1 on page 21)
			It moves selection up.
			It moves selection down.
			It confirms selection and goes to the following phase
			It moves selection up by one page.
			It moves selection down by one page.
			It moves selection to list top.
			It moves selection to list bottom.

NOTE: To speed up selection phase, you can type the name of vehicle make or model, or part of them, on the PC keyboard, and then scroll the list until finding the desired one.

8.3 Selected Vehicle Technical Specification Displaying

When selecting a vehicle (see par. 8.2 on page 21), a page showing the measurements and tolerances supplied by the manufacturer is displayed.



Figure25

	SENS. KEYBOARD	PC KEYBOARD	DESCRIPTION
			It goes back to vehicle selection (par.8.2 on page 21)
			See (*) Key description
			It displays vehicle technical specifications next page, and any graphic animation See (*) Key description
			It changes rim diameter value
			It goes to out-of-centre operations (para. 8.4on page25)

(*) Key description

Possibility to enter chassis height or kingpin data, as envisaged by the manufacturer	Press F5 To display any graphic animation

8.4 Preliminary operations

8.4.1 Preliminary vehicle control operations

Before starting the check the geometric setup of a vehicle, the following checks must be made:

- Check and if necessary eliminate any play on the suspensions and steering linkages
- Check and if necessary eliminate any possible hardening or give of the elastic suspension parts
- Adjust the pressure of the tyres to those indicated by the manufacturer.
- Position and share out any loads as required by the manufacturer.

8.4.2 Preparing for run out

After displaying the vehicle technical data page (see para. 8.3 page 24), proceed to prepare the vehicle for the run out procedure as follows:

- Fit wheel clamps and sensors on the wheels
- Lift the vehicle off the lift platforms (if were carried out the raised wheels Run-out)
- Block the turnplates



Figure26

	SENS. KEYBOARD	PC KEYBOARD	DESCRIPTION
			It goes back to previous page
			Selection run-out raised wheels (para. 8.5.1on page26) Or run-outpushing (par. 8.5.2 page29)
			It goes to run-out operations (para. 8.5on page26)

Note:In this phase, the pictures showing the 4 batteries of the measuring heads are displayed with the relevant residual charge %.

8.5 Runout

The run out procedure is useful for offsetting any rim and wheel clamp unbalance. This procedure need not necessarily be done by selecting key F4.







This procedure can also be started after adjusting the vehicle by selecting the specific menu option (See para. 8.14).

To perform the run out procedure, preparations must have been made as explained in para. 8.4.2 page 25.

8.5.1 Run out raised wheels



Figure27

	SENS. KEYB.	PC KEYBOARD	DESCRIPTION
			Return to run out preparation (para 8.4.2on page 25)
			Performs measurement preparation (para8.6. on page34)

It is recommended to thoroughly comply with the displayed instructions.

During the start phase, the central keys of the displayed keypads are flashing, to indicate which key has to be pressed to start the procedure. It is neither necessary to start from a special wheel, nor to proceed according to a defined key order (seeFigure27).

The procedure should be carried out on all four wheels so, on the monitor, detector keypad central keys will flash so as to suggest that you start the procedure by pressing the special key (see Figure27). During configuration, you can set the Run-Out procedure in 2 or 3 points. The example shows a 3-point procedure.

When keypad central key is pressed, the following screen will be displayed:

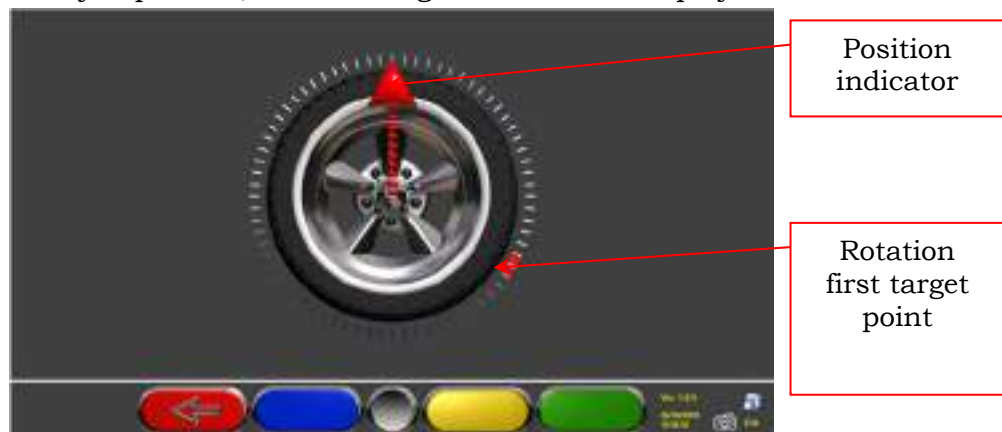

Figure28

Figure28shows wheel current position.

Upon procedure start, a “self-calibration” is carried out so that the position indicator is facing up. Turn wheel rim by hand so as to allow the real-time displaying of wheel position and of the corresponding position indicator. Update is made approx. every 3 times a second. The first target is to turn wheel by 120° and reach the first highlighted point. Rotation can be made in both directions, but it is nevertheless recommended to follow the direction shown by the arrow to reach the indicated position more quickly.

Turn wheel by 120° and, once the target position is reached, press detector keypad central key, as indicated on the screenFigure29.



Figure29

La Figure30is displayed for approx. three seconds, which are enough for the programme to acquire measurement readings. The red LED previously flashing on detector keypad (par.3.7.4on page 10) will turn off during data acquisition; then it will flash again:



Figure30

ANow you shall turn wheel until position indicator matches the second point, positioned at about 240° from the starting position.



Figure31

Turn wheel by 240° and, once the target position is reached, press detector keypad central key, as indicated on the screen Figure29.

The last phase consists in taking wheel back to the starting point: third point. Once last rotation (to go back to starting position) has been carried out, programme acquires the last measurement readings. The screen Figure30 will be displayed again for approx. three seconds. After measurement acquisition, programme will automatically continue, and the following screen will be displayed:

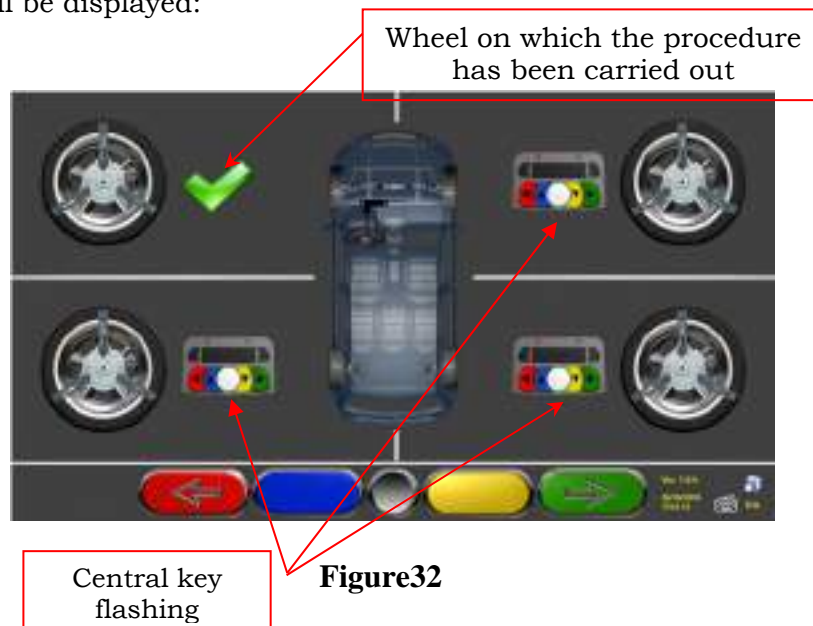

Figure32

On Figure32 the front left wheel is shown with a tick on the side, to indicate that the procedure has been carried out on that wheel. Procedure can anyway be repeated by pressing again the central key of the concerned detector. When the Run-Out procedure has been completed on all wheels, programme will automatically go to the next phase.

NOTE: Watching the monitor during this procedure could sometimes prove difficult, mainly when working on rear wheels.

To prevent this problem, the Run-Out three acquisition points can be easily associated to the position of the 3 clamp arms (if made on 3 points) or to the 2 clamp sides with 4 points (if made on 2 points).

The different phases can be followed by looking at the red LED on the keypad of each detector:

Red LED flashes when wheel has to be turned.

Red LED turns off when one of the three points is being sampled

Red LED is steady when the procedure has been completed.

NOTE 2 : During system configuration, you can also define that procedure is carried out on 2 points instead of 3. This means that wheel will be turned twice by 180°, instead of being turned three times by 120°, as described above.

8.5.2 Thrust Run-Out with Automatic Acquisition

To carry out the thrust Run-Out with automatic acquisition procedure, press F3  to select “thrust Run-Out” during the preliminary operations (see par. 8.4.2 on page 25). The following screen will be displayed:



Figure33

To carry out the thrust Run-Out operation, it is recommended to carefully follow the displayed instructions.

RELEASE detectors, so that they are free to oscillate upon wheel movement. Wait for detectors to stop oscillating, and start moving vehicle backwards, very slowly, until the rotation of the wheel has turned 30 degrees. You can observe this rotation on the 3-point races of the clamps.

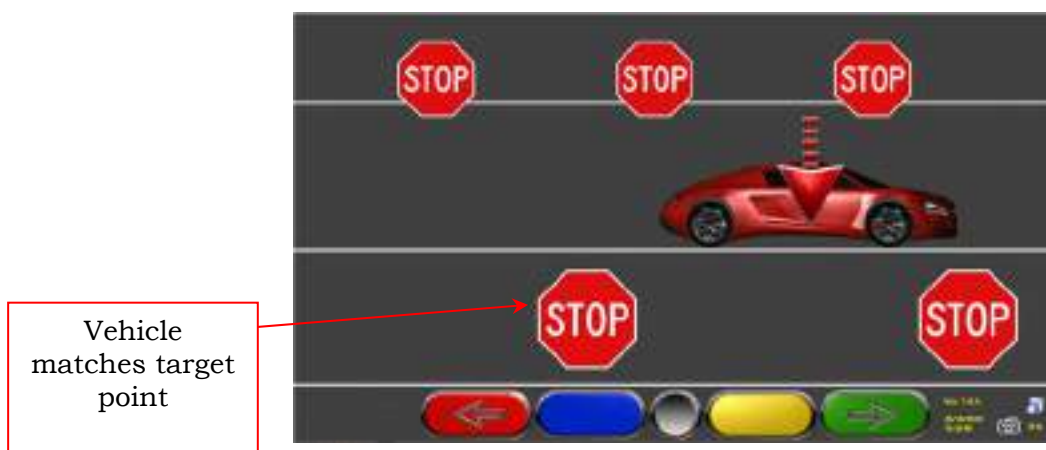

Figure34

As soon as vehicle matches target point, wait for detectors to stop oscillating. "STOP" will be displayed for approx. three seconds, which are enough for the programme to acquire measurement readings. Then the following screen will be displayed:

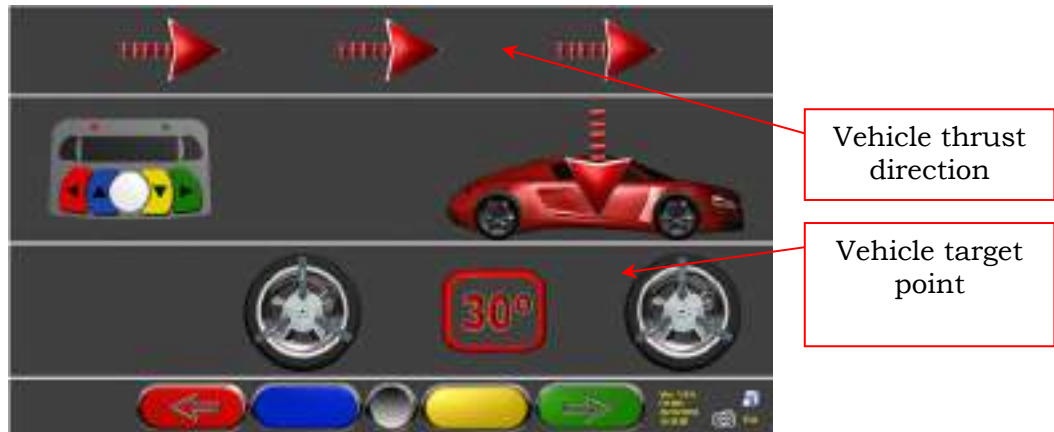

Figure35

Move vehicle forward again, until the rotation of the wheel did not make back 30 degrees forward (final point). "STOP" will be displayed for approx. three seconds, and measurement readings acquired. The thrust Run-Out procedure has been completed.

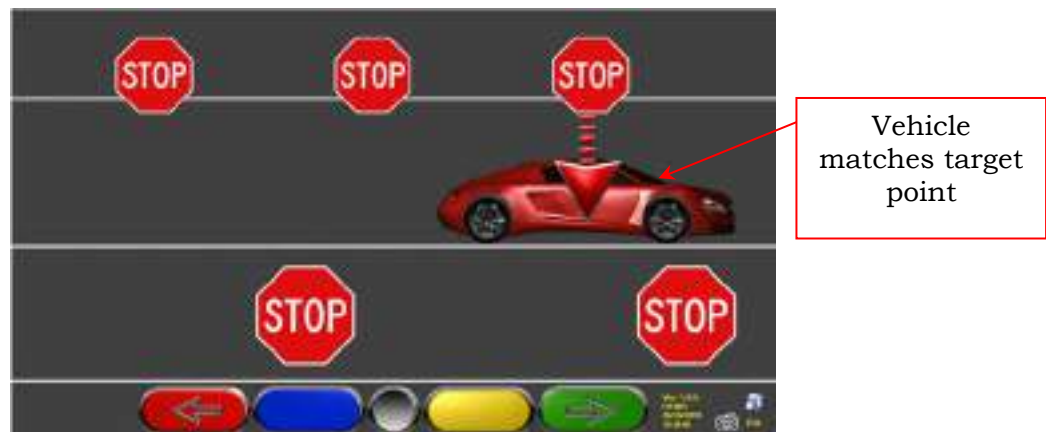

Figure36

Should you be willing to repeat the operation once the programme has already entered a following phase, you can go back to this page by pressing F1, and repeat the above procedure. Once the Run-Out procedure has been completed, programme will automatically go to the next phase.

8.5.1 Inclinometer-controlled Thrust Run-Out

Inclinometer control during the thrust Run-Out procedure is used to measure more accurately the rotation angle pertaining to the calculation.

From the Run-Out configuration menu, set – Thrust Run-Out → “inclinometer”.

Lower the reference detector (usually it is the left front one) until its end is almost touching the ground, then lock it in place. RELEASE the other detectors, so that they are free to oscillate upon wheel movement. When finished, press central key to confirm.



Figure37

SpMove vehicle back, very slowly, until reference sensor reaches the target position (end up - see Figure38). When finished, press central key to confirm.



Figure38

Position reference sensor horizontally - clearly levelled - and, when finished, press central key to confirm.

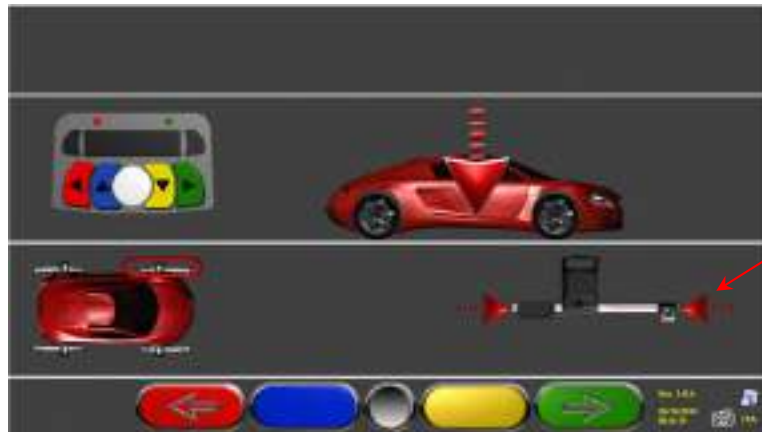

Reference
sensor
horizontal
position

Figure39

“STOP” is displayed for approx. three seconds, which is enough for the programme to acquire measurement readings.

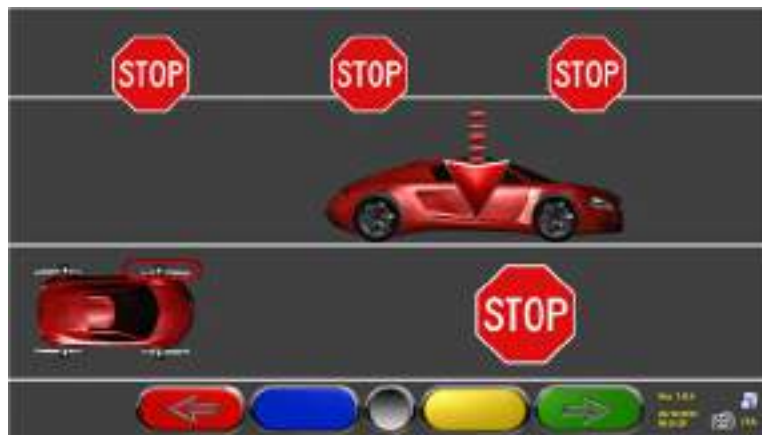

Figure40

Position reference sensor again with the end up, almost in the "target" position reached in Figure41 and, when finished, press central key to confirm..



Reposition
the reference
sensor as
"target".

Figure41

Move vehicle forward, very slowly, until reference sensor reaches again almost the start position. When finished, press central key to confirm.

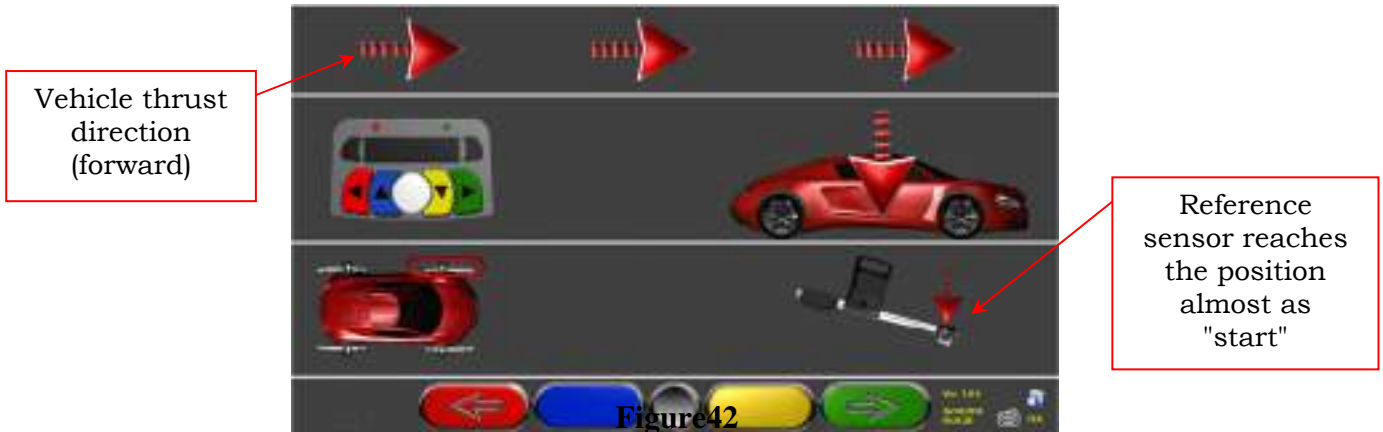

Figure42

Position reference sensor horizontally - clearly levelled - and, when finished, press central key to confirm.

“STOP” is displayed for approx. three seconds, which is enough for the programme to acquire measurement readings.



Figure43

The thrust Run-Out procedure with “inclinometer control” has been carried out.







Should you be willing to repeat the operation once the programme has already entered a following phase, you can go back to this page by pressing F1, and repeat the above procedure. Once the Run-Out procedure has been completed, programme will automatically go to the next phase.

8.6 Measurement Preliminary Operations

After having carried out the Run-Out procedure as explained in par. 8.5 on page 26, vehicle shall be prepared for measurement readings. The following screen will be displayed:



Figure44

	SENS. KEYB.	PC KEYBOARD	DESCRIPTION
			It goes back to Run-Out procedure (par. 8.5 on page 26)
			It continues to the alignment procedure (par. 8.7 on page 35)

- 1) Lower vehicle so as to make wheels rest on lift platforms (of course, only if the Run-Out procedure has been carried out with raised wheels)
- 2) Release front plates, and any rear platform
- 3) Brake wheels with hand brake, and lock brake pedal with the special tool (this operation is necessary when carrying out a steering for kingpin correct calculation).
- 4) Settle vehicle front and rear ends (this operation shall be carried out only if the Run-Out with raised wheels procedure has been performed).



Press  to continue.

8.7 Detectors Alignment and Levelling

To proceed to detectors alignment and levelling procedure, you should have first carried out measurement preliminary operations, as explained in par. 8.6 on page 34.



Figure45

	SENS. KEYB.	PC KEYBOARD	DESCRIPTION
			It goes back to measurement preliminary operations. (par. 8.6 on page 34)

Turn steering wheel from left to right, or vice-versa, until wheels are aligned, namely until display level is not perfectly centred.

Adjust detectors until they are levelled, and lock them in place by turning the special knobs. This operation shall be carried out on all four detectors.

Rear detectors also feature special 3-LED indicators (par. 3.7.5 on page10) flashing based on detectors levelling.

If front wheels are too misaligned, no levelling will be displayed.

NOTE: Once detector alignment and levelling operations are completed, the “STOP” images will be displayed under the alignment level to indicate that the programme is acquiring vehicle data measurements. Now also detector calibration check is carried out. Programme will automatically continue only after detectors are correctly aligned and levelled.

WARNING: The vehicle being diagnosed could feature a front spoiler preventing communication among detectors. Should this be the case, the special “spoiler” procedure will be automatically started. Follow the displayed graphic representation, and lower front sensors so that the transducers positioned onto arm end are below the spoiler. System acquires front toe measurement, and then the alignment and levelling procedure of Figure45 will be displayed again. Align and level, the programme will continue automatically.

8.8 Steering Procedure

Once detectors are aligned and levelled (see par. 8.7 on page 35), the steering procedure can be carried out in order to define:

- Caster
- Kingpin
- Included angle



Figure46

	SENS. KEYB.	PC KEYBOARD	DESCRIPTION
			Repeat alignment and levelling procedure (par. 8.7 on page 35)
			Press this key to select the type of steering to be made. (*)
			It displays vehicle diagnosis page (par. 8.9 on page 37)

(*) Type of steering to be made:

- Steering at 20°
- ACK steering (at 20° with Toe-out on turn)
- Steering at 10°
- Max. steering with rotating plates with ENCODER (optional)

Steering procedure can also be skipped: the values of the above-specified data measurements will not be available. To skip the procedure, press F4 to directly display vehicle diagnosis page.

Should the procedure not be carried out at this stage but only at the end of adjustments, you can select the corresponding option from the menu.

8.9 Vehicle Diagnosis

After having carried out the steering procedure (see par. 8.8 on page 36), a diagnosis page showing a summary of the operations carried out on vehicle rear axle (Figure47) will be displayed.



Figure47

	SENS. KEYB.	PC KEYBOARD	DESCRIPTION
			Repeat steering procedure. (par. 8.8 on page36)
			It changes values displaying layout
			It displays vehicle technical specifications (it may be changed, if needed). (par. 8.3 on page 24)
			It displays diagnosis page with a summary of front axle measurements (Figure48)

Press F4 to display the diagnosis page with a summary of front axle measurements (Figure48). If you press F3 from here , programme will allow the printout of diagnosis measurements.

Press F4 to continue with data adjustment, programme will display Figure49, press F4 again to confirm.



Figure48



Figure49

Now you can prepare vehicle for adjustment (see par. 8.10 on page 38), confirm with F4 (Figure49).

8.10 Adjustment Preliminary Operations

Select F4 from Figure49 (see par.8.9 on page 37) to carry out adjustment preliminary operations. Follow the displayed instructions to carry out adjustment preliminary operations. Press F4 to continue.

1. Place steering wheel in straight position.
2. Lock steering wheel with the special tool, and continue.



Figure50

8.11 Rear Axle Adjustment

Rear axle adjustment procedure can be made by pressing F4 from Figure50 after having carried out adjustment preliminary operations (par. 8.10 on page 38).

Proceed to adjustment, where allowed, as follows:

- Rear camber - Rear partial toe



Figure51

	SENS. KEYB.	PC KEYBOARD	DESCRIPTION
			It changes values displaying layout (large numbers/large cursors)
			“Jack-Hold” procedure (adjustment with raised wheels)
			It displays vehicle technical specification page. (par. 8.3 on page 24)
			It continues to front axle adjustment. (par.8.12 on page 39)

8.12 Front Axle Adjustment

Front axle adjustment procedure is launched by selecting in the rear axle adjustment page (Figure56) after having carried out adjustment preliminary operations (see par. 8.10 on page 38).

To adjust angles, the correct sequence is the following: CASTER – CAMBER – TOE.

WARNING: When entering this stage, caster values are “FROZEN”.

To “de-freeze” these values, you can press Shift+F5 at the same time when the measurement selection “R” is on caster measurement values, or select F2 to display a menu page with additional functions (par. 8.14 on page 42). Now select “Caster Adjustment”.

Once caster values have been adjusted or, even if they are not adjusted as they are deemed to be correct, it is recommended to “FREEZE” again these values. This procedure prevents caster values from varying in case detectors are inadvertently moved.















To this end, take measurement selection “R” (see Figure52) onto the caster values, and proceed as described above.

A grid will be displayed onto caster values, to indicate that they are “frozen”.

Then adjust front axle



Figure52

	SENS. KEYB.	PC KEYBOARD	DESCRIPTION
			Repeat steering procedure. (par. 8.8 on page36)
			Jack-Hold” procedure (adjustment with raised wheels)
			Selection key of the measurement to be adjusted.
			It proceed with Front Toe Adjustment at steered wheels. See par. 8.12.1
			It proceed to summary of test and adjustment data(par.8.13onpage41)

8.12.1 Front toe Adjustment at steered wheels

Front Toe adjustment procedure at Steered Wheels is launched by selecting in the front axle adjustment page, by pressing key F3 .



Appears the below indicated Figure, that asks to steer Left or Right and then to press F5 to confirm.



Figure53

Note: the Steering level indicator is displayed only to give to the operator the feedback to remain within maximum alignment angles reading (until 22÷24 degrees).











Once the F5 is pressed, appears the picture indicated in Figure54, where it is possible to see the measurement values now frozen.

To adjust LH or RH partial toe, simply before unfreeze the value by F2  or F3  (LH toe - RH toe).

Then when finished to adjust, press the key F1  to go back in the front adjustment phase (par. 8.12). The program asks to steer again approximately in the middle, before giving again the page of front axle measurements (Figure52).



Figure54













	SENS. KEYB.	PC KEYBOARD	DESCRIPTION
		 	It asks to steer again in the middle before displaying the front axle measurements.
			Unfreeze/Freeze the Front LH Partial TOE
			Unfreeze/Freeze the Front RH Partial TOE

8.13 Summary of Test and Adjustment data

This display page appears when all vehicle adjustments have been made, after press the key F4 from front axle adjustment, see Figure 52.



Figure 55

	SENS. KEYB.	PC KEYBOARD	DESCRIPTION
			It displays additional options menu (par 8.14, page 42)
			It displays vehicle technical specification page (par. 8.3, page 24)
			Operations completed ! Customer data entry (par. 8.15 a page 43)
			It proceed back again to Rear Adjustment (par. 8.11 page 38)

8.14 Additional Functions Menu

To carry out some additional operations or to repeat some of programme phases (in case they have not given satisfactory outcomes or have not been carried out at all), select F1  in the “Summary of Test and Adjustment data” display page (see par.8.13, page 41).

You will access an additional function menu allowing carrying out the following procedures:

PRELIMINARY OPERATIONS: see par. 8.4.1 on page 25

TOE CURVE: Toe curve can be adjusted by following the displayed figures, as follows:

- Settle vehicle, press F4
- Position the special tool under front axle, press F4
- Adjust front partial toe, as recommended by the manufacturer, press F4
- Remove tool from axle, and press F4. Programme will go back to the adjustment phase.

















CHASSIS DIAGNOSIS: A graphic-geometrical representation of the axles of the vehicles you are working on can be displayed.

DATABASE: It allows displaying vehicle selection page (8.2 on page 21) and, if needed, selecting a different vehicle

CASTER ADJUSTMENT: see par. 8.12 on page 39.



Figure56

	SENS. KEYB.	PC KEYBOARD	DESCRIPTION
		 	It goes back to summary (par 8.13, page 41)
		 	It moves selection up.
		 	It moves selection down.
		  	It confirms selection.

8.15 Printout of Measurements taken

By selecting the following key from the customer data entry page,



the following screen will be displayed:



Vehicle and customer data entry

Figure57

	SENS. KEYB.	PC KEYBOARD	DESCRIPTION
			It goes back to summary (par 8.13, page 41)
			It stores the carried out diagnosis inside a special "customer database" so as to allow test later displaying (par. 8.14 on page 42)
			It displays a print preview of the test carried out (par. 8.15 on page 43)
			It goes back to start page without storing test



Figure58

	SENS. KEYB.	PC KEYBOARD	DESCRIPTION
			It goes back to “vehicle data entry” phase of Figure57
			It allows selecting a printer different from the pre-set one
			It sends print report to printer
			It allows defining colours on the printout of out-of-tolerance data (Red to highlight them or Black NOT to highlight them)

A report on the performed test is printed with customer data, vehicle data before and after adjustment, vehicle technical specifications supplied by manufacturer, and any other remarks for the customer.

To access the data contained inside customer database, press F3  from the start page (see Figure21)

Legend of the printout example shown in the previous page (Figure59).

- 1 - logo of the manufacturer
- 2 - dedicated to workshop data customisation
- 3 - Test date and time
- 4 - Vehicle being tested and vehicle owner data
- 5 - Vehicle being tested manufacturing data
- 6 - Vehicle being tested diagnosis data
- 7 - Vehicle being tested data after adjustment
- 8 - Front axle data table
- 9 - Rear axle data table
- 10 - devoted to manual remarks

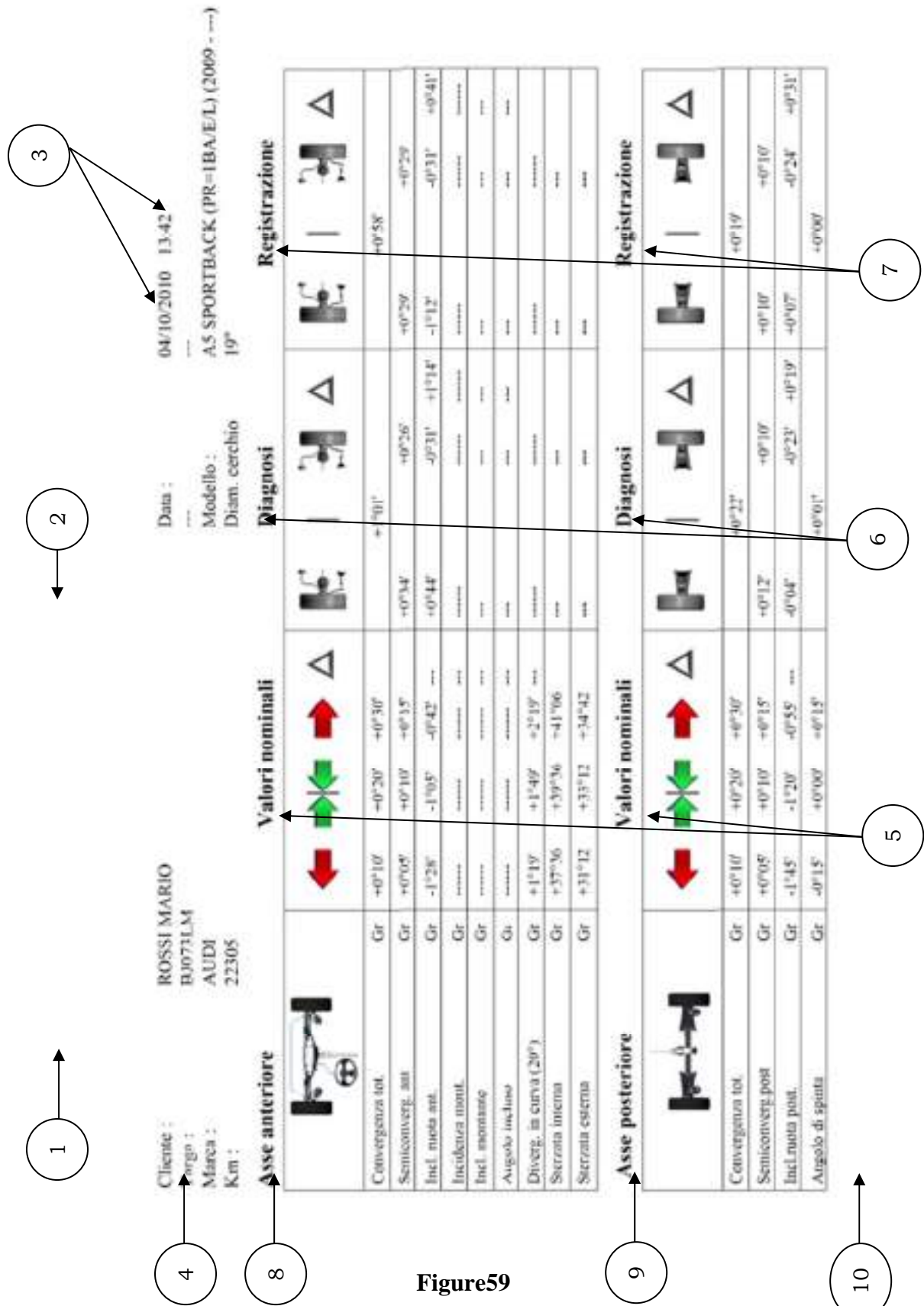











Figure59





9 TESTING AND ADJUSTING A HEAVY DUTY VEHICLE





In the next chapters are illustrated some example of procedures for the adjustment of heavy duty vehicles. Selecting one of those vehicles from data bank, it is necessary follow the indications as illustrated in the next chapters.

9.1 Adjusting a 3 axles tractor







	<p>From the first Logo page press the key F4, entering in data Bank selection</p>
	<p>Select the group TRUCKS Press F4 to proceed</p>
	<p>Chose the tractor from the TRUCK data bank or select it from the standard prospect (1st icon of the list). Press F4 to proceed</p>
	<p>Select Tractor and press F4 to proceed</p>

	<p>Select e.g. a Tractor 6x4 (6 wheels - 4 wheels engine)</p> <p>Press F4 to proceed</p>
	<p>Confirm with F4 the 3 axle tractor selected. It is possible to change the rear axle (2nd or 3rd) where to start, in order to take it as 2nd axle of basic vehicle.</p> <p>Press key F5  to change it.</p> <p>Note: It is also possible to change the type of tractor now, changing the number of axles by F3</p>
	<p>Display of technical data of selected vehicle. The data displayed are of the 1st rear axle, move the rear axle selected by F2</p> <p>Press F4 to proceed</p>
	<p>Display of instruction page, wait until automatically appear the next page or press F4 to skip it</p>

	<p>Mount the Front sensor heads in the front axle Mount the Rear sensor heads in the 2nd rear axle (conventionally the Front Sensor are displayed BLUE and the Rear are RED) Press F4 to proceed</p> <p>Note: On next step should be executed the Run Out. It will be possible anyway to hide it (set in the configuration parameters , see chap.7).</p>
	<p>Unlock the turntables and lock the brake pedal using the tool provided. Wait until automatically appear the next page or press F4 to proceed.</p>
	<p>Turn the steering until the wheels are aligned, meaning until the display unit level is perfectly at centre. Regulate the 4 sensors until they are levelled and brake them by means of the knobs provided. Wait until automatically appear the next page</p>
	<p>Perform the steering procedure following the display unit level on the screen, first left then right then at centre. The steering procedure can also be jumped by F4; the Caster data measurements will not appear.</p>

	<p>Center the steering wheel and/or the steering box</p> <p>Lock it with the proper tool</p> <p>Wait until automatically appear the next page or press F4 to proceed</p>																						
	<p>Adjust the rear thrust angle where is possible and needed on the rear axle.</p> <p>Note: from this page and from any page where is indicated adjustment angles by pressing the key "Ins"  appears the below indicated table that specify the shim thickness related to angles variation.</p> <p>Press F4 to proceed</p>																						
 <table border="1" data-bbox="303 1019 646 1254"> <thead> <tr> <th>Dg</th> <th>In</th> </tr> </thead> <tbody> <tr><td>5.00 - 5.34</td><td>1.00"</td></tr> <tr><td>5.36 - 5.67</td><td>1.18"</td></tr> <tr><td>5.68 - 6.18</td><td>1.33"</td></tr> <tr><td>6.19 - 6.14</td><td>1.50"</td></tr> <tr><td>6.15 - 6.54</td><td>1.67"</td></tr> <tr><td>6.55 - 6.71</td><td>1.84"</td></tr> <tr><td>6.72 - 6.95</td><td>2.00"</td></tr> <tr><td>6.96 - 6.97</td><td>2.16"</td></tr> <tr><td>6.98 - 6.98</td><td>2.33"</td></tr> <tr><td>6.99 - 6.94</td><td>2.50"</td></tr> </tbody> </table>	Dg	In	5.00 - 5.34	1.00"	5.36 - 5.67	1.18"	5.68 - 6.18	1.33"	6.19 - 6.14	1.50"	6.15 - 6.54	1.67"	6.55 - 6.71	1.84"	6.72 - 6.95	2.00"	6.96 - 6.97	2.16"	6.98 - 6.98	2.33"	6.99 - 6.94	2.50"	<p>Take note of the shim thickness and press F1 to return back previous page.</p>
Dg	In																						
5.00 - 5.34	1.00"																						
5.36 - 5.67	1.18"																						
5.68 - 6.18	1.33"																						
6.19 - 6.14	1.50"																						
6.15 - 6.54	1.67"																						
6.55 - 6.71	1.84"																						
6.72 - 6.95	2.00"																						
6.96 - 6.97	2.16"																						
6.98 - 6.98	2.33"																						
6.99 - 6.94	2.50"																						
	<p>With the Key F3 it is also possible to zoom and unzoom the partial Toe angles, seeing also the Total Toe and Camber.</p> <p>Press the Key F4 to proceed.</p> <p>Press Shift +F5 to get the partial toe displayed with big digits and Shift +F5 again to get again small</p>																						

	<p>Re Adjust the front axle, Caster, Camber and Toe where is possible and needed. Press F4 to proceed</p> <p>Press F3 to repeat the steering procedure or F1 to return rear axle adjustment</p>
	<p>Move the Front sensor heads from the front axle to 1st rear axle, Press F4 to proceed. Important: Keep stopped the steering wheel and/or the steering box. Note: It is possible to skip this axle pressing F2, or skip all the axles remained going directly in the summary page pressing F3.</p>
	<p>Level only the Front heads (mounted on the 1st rear axle), leaving the Rear sensor in their position, and wait until automatically appear the next page.</p>
	<p>Adjust the SCRUB ANGLE referred to the front axle, as indicated on the picture beside. As illustrated the 1st rear axle must be turned anticlockwise</p>
	<p>When finish adjusting press F4 to proceed.</p>





	<p>With the Key F3 it is also possible to zoom and unzoom the scrub angle, seeing also the Toe and the Camber angles. Press the Key F4 to proceed.</p>
	<p>If is necessary to adjust now the set-back ("Set-Back LIVE") during adjustment phase of an axle, press the key Alt , appears a new keys sequence. Press the key F3 , appear the picture beside indicated, that represent the set-back angles in real time. After having eventually adjusted the angle, press F1 in order to exit. I will be requested to align again the wheels before proceed.</p>
	<p>Appears the Summary page, representing Diagnosis and adjustment data. Press F1 to enter in the page where is possible to print or save data Press F2 to display set back graphics Press F3 to select axle and display those data Press F4 to select repeat the axle displayed. Attention: Adjusting the front Axle again, need to adjust again also the rear ones.</p>
	<p>When F1 is pressed appears the page beside indicated, where is possible to print data by F3 or store in the personal Data Bank by F2. Press F4 to return first Logo page.</p>

NOTE: It is possible to get also partial summary pages after have done any single axles, with diagnosis data and adjustment data This summary pages will appear or not depending on what is set in the configuration parameters.(see chap. 7).

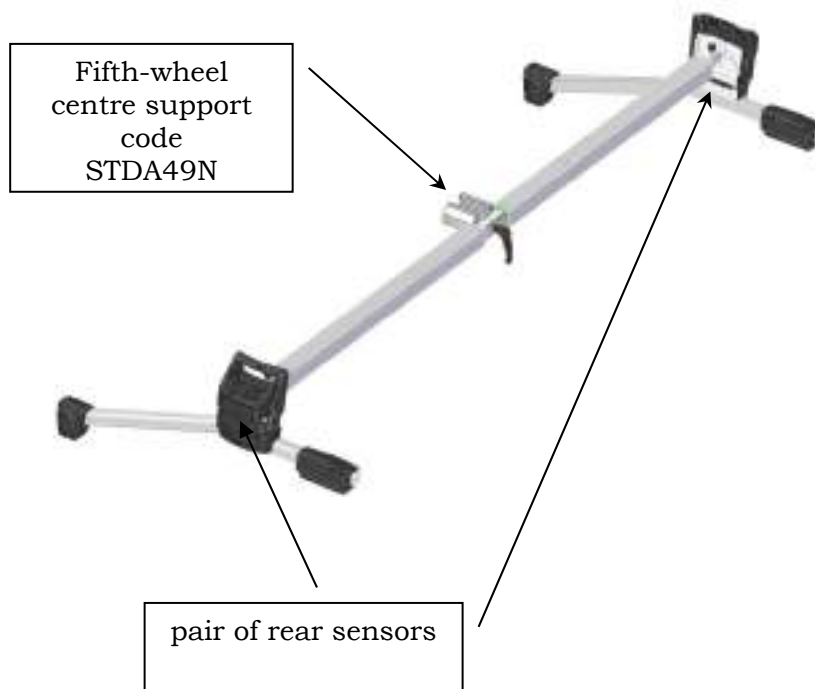



9.2 Adjusting a semi-trailer with 3 back axles

IMPORTANT: To make this type of adjustment, also require the “Fifth-wheel” centre support code STDA49N.



	<p>Select a semi- trailer from the data bank</p>
	<p>Select a 3 axle semi- trailer</p>
	<p>Confirm with F4 the 3 axle semi- trailer selected</p> <p>Note: It is also possible to change the selection now, changing the number of axles by F3</p>
	<p>Display Of Technical Data Of Selected Vehicle The data displayed are of the 1st axle, move the axle selected by F2</p> <p>Press F4 to proceed</p>





	<p>Mount the trailer King-pin. Mount the front sensor heads on the last axle.</p> <p>Press F4 to proceed</p>
---	--





	<p>Level the heads and wait until automatically appear the next page.</p>
	<p>Adjust the Toe and the trust angle where is possible and needed on the last semi-trailer axle. Press F4 to proceed</p>
	<p>Mount now the Rear sensor heads on the 1st axle (conventionally the Front Sensor are displayed BLUE and the Rear are RED) Remove the trailer King-pin.. Press F4 to proceed</p> <p>Note: It is possible to skip this axle pressing F2, or skip all the axles remained going directly in the summary page pressing F3.</p>
	<p>Level the Rear heads (mounted on the 1st axle), leaving the front sensor in their position, and wait until automatically appear the next page.</p>
	<p>Adjust the SCRUB ANGLE referred to the last Axle as indicated on the picture beside. Adjust eventually also the thrust Angle.</p>



 <p>The screenshot shows a digital display with several metrics: 'Camber L' at -0.48°, 'Camber R' at -0.12°, 'Total Scrub' at -1.14°, and 'Scrub angle' at +0.02°. There are various control buttons and wrench icons around the display.</p>	<p>With the Key F3 it is also possible to zoom and unzoom the scrub angle, seeing also the Toe and the Camber angles.</p> <p>Press the Key F4 to proceed.</p>
 <p>The screenshot shows a 3D model of a vehicle's rear axle assembly. The wheels and suspension components are visible, with some parts highlighted in green. There are control buttons at the bottom.</p>	<p>Proceed now adjusting the second axle as done for the first one.</p> <p>Move the Rear sensor heads from 1st axle to the 2nd, Press F4.</p> <p>Level the heads and proceed adjusting the Scrub and offset angle, at the end press F4.</p> <p>Note: It is possible to skip this axle pressing F2, or skip all the axles remained going directly in the summary page pressing F3.</p>
 <p>The screenshot shows a 'Summary' page titled 'Semi-Trailer 3 Axis'. It is divided into 'Diagnosis' and 'Adjustment' sections. The 'Diagnosis' section lists various parameters like 'Camber L', 'Camber R', 'Total Scrub', 'Scrub angle', 'Offset L', and 'Offset R'. The 'Adjustment' section has corresponding buttons for each parameter. There are also control buttons at the bottom.</p>	<p>Appears the Summary page, representing Diagnosis and adjustment data.</p> <p>Press F1 to enter in the page where is possible to print or save data</p>





NOTE: It is possible to get also partial summary pages after have done any single axles, with diagnosis data and adjustment data. This summary pages will appear or not depending on what is set in the configuration parameters (see chap. 7)..



9.3 Adjusting a 3 axles tractor - 2 steering axes

	<p>Select a tractor from the data bank</p>
	<p>Select a tractor with 2 steering axes</p>
	<p>Confirm with F4 the tractor with 2 steering axes selected Note: It is also possible to change the selection now, changing the type by F2 or F3</p>
	<p>Display Of Technical Data Of Selected Vehicle The data displayed are of the 1st axle, move the axle selected by F2</p> <p>Press F4 to proceed</p>





	<p>Mount the Front sensor heads in the 1st front axle</p> <p>Mount the Rear sensor heads in the rear axle (conventionally the Front Sensor are displayed BLUE and the Rear are RED)</p> <p>Press F4 to proceed</p>
	<p>Unlock the turntables and lock the brake pedal using the tool provided.</p> <p>Wait until automatically appear the next page or press F4 to proceed</p>
	<p>Turn the steering until the wheels are aligned, meaning until the display unit level is perfectly at centre.</p> <p>Regulate the 4 sensors until they are levelled and brake them by means of the knobs provided.</p> <p>Wait until automatically appear the next page.</p>
	<p>Perform the steering procedure following the display unit level on the screen, first left then right then at centre.</p> <p>The steering procedure can also be jumped by F4 ; the Caster data measurements will not appear.</p>
	<p>Center the steering wheel and/or the steering box</p> <p>Wait until automatically appear the next page or press F4 to proceed</p>

	<p>Adjust the rear thrust angle where is possible and needed on the rear axle. Press F4 to proceed</p>
	<p>With the Key F3 it is also possible to zoom and unzoom the partial Toe angles, seeing also the Total Toe an camber. Press the Key F4 to proceed.</p>
	<p>Adjust the front axle, Caster, Camber and Toe where is possible and needed. Press F4 to proceed</p> <p>Press F3 to repeat the steering procedure or F1 to return rear axle adjustment</p>
	<p>Turn the steering until the wheels are aligned, meaning until the display unit level is perfectly at centre.</p> <p>Level again the Front heads (mounted on the 1st steering axle), leaving the rear sensor in their position, and wait until automatically appear the next page.</p>
	<p>Move the Front sensor heads from 1st steering axle to the 2nd , then press F4.</p> <p>Note: It is possible to skip the steering procedure on this axle by pressing F2, or skip all the axles remained going directly in the summary page pressing F3.</p> <p>Important: Keep the steering wheel and/or steering box stopped.</p>

	<p>Level again the Front heads (mounted on the 2nd steering axle), leaving the rear sensor in their position, and wait until automatically appear the next page.</p>
	<p>Perform the steering procedure for the 2nd steering axle following the display unit level on the screen, first left then right then at centre. The steering procedure can also be jumped by F4 ; the Caster data measurements will not appear.</p>
	<p>Adjust the 2nd steering axle, Caster and Camber where is possible and needed. Press F4 to proceed.</p> <p>Press F1 to return back steering procedure</p>
	<p>Move the Front sensor heads from 2nd steering axle to the 1st, then press F4.</p>
	<p>Turn the steering until the wheels are aligned, meaning until the display unit level is perfectly at centre.</p> <p>Level again the Front heads (mounted on the 1st steering axle), leaving the rear sensor in their position, and wait until automatically appear the next page.</p>

	<p>Move the Rear sensor heads from rear axle to the 2nd steering axle, Press F4 to proceed.</p> <p>Important: Keep stopped the steering wheel and/or the steering box.</p> <p>Note: It is possible to skip the toe adjust on this axle by pressing F2, or skip all the axles remained going directly in the summary page pressing F3.</p>
	<p>Level the Rear heads (mounted on the second steering axle), leaving the front sensor in their position.</p> <p>Wait until automatically appear the next page.a.</p>
	<p>Adjust the 2nd steering axle, Camber (must be before unfrozen) and Toe where is possible and needed. Press F4 to proceed</p> <p><i>NOTE: In this page is not allowed to adjust caster because it has eventually been done previously. After will appear the summary page and where is possible to print data or store in the personal Data Bank.</i></p>

9.4 Adjusting a full trailers 2+1

	<p>elect a Full-Trailer in the database</p>
	<p>Select a full trailer with 2 tongue front axles and 1 rear axle</p>
	<p>Confirm with F4 the full trailer selected</p> <p>Note: It is also possible to change the selection now, changing the type by F2 or F3</p>
	<p>Display Of Technical Data Of Selected Vehicle</p> <p>The data displayed are of the 1st axle, move the axle selected by F2°</p> <p>Press F4 to proceed.</p>
	<p>Mount the Front sensor heads in the 1st front axle</p> <p>Mount the Rear sensor heads in the rear axle</p> <p>(conventionally the Front Sensor are displayed BLUE and the Rear are RED)</p> <p>Press F4 to proceed</p>

	<p>Steer the tongue straight ahead, meaning until the display unit level is perfectly at centre. Regulate the sensors until they are levelled and brake them by means of the knobs provided.</p> <p>Wait until automatically appear the next page</p>
	<p>Adjust the rear thrust angle where is possible and needed on the rear axle.</p> <p>Press F4 to proceed</p>
	<p>Adjust the 1st front axle, Camber and Toe where is possible and needed.</p> <p>Press F4 to proceed</p>
	<p>Move the Rear sensor heads from rear axle to the 2nd front axle, Press F4 to proceed.</p> <p>Important: Keep the tongue stopped.</p> <p>Note: It is possible to skip this axle pressing F2, or skip all the axles remained going directly in the summary page pressing F3.</p>
	<p>Level the Rear heads (mounted on the second front axle), leaving the front sensor in their position.</p> <p>Wait until automatically appear the next page.</p>

	<p>Adjust the 2nd front axle, Camber and Toe where is possible and needed.</p> <p>Press F4 to proceed</p>
	<p>Appears the Summary page, representing Diagnosis and adjustment data.</p> <p>Press F1 to enter in the page where is possible to print or save data</p> <p>Press F2/F3 to select axle and display those data</p> <p>Press F4 to select repeat the axle displayed</p>

10 DATABASE CUSTOMISATION

Vehicle database can be customised by creating customised groups and vehicles.

10.1 New Group Entry

To create customised groups and store them inside database, the group configuration page shall be displayed (see par. 7.1 on page 19).

Press “Ins” on the keyboard



The following screen will be displayed:



Figure 60

Type the name of the new profile (the example Figure 60 shows “ITALIA”), and press F4 to confirm.



Figure61

Now press F4 to enter the new “ITALIA” group and display the available makes with F5, as specified in Figure20. Then display profile, always pressing F5, as described here below in Figure62.

Press F1 to quit.



Figure62

10.2 New Group Deletion

You have to display the group configuration (see par. 7.1 on page 19), select the customised group you want to delete, then press "cancel"  : , and press F4 to confirm.



Figure63

Warning: If a customised group is deleted, it will no longer be possible to restore it, unless you have a database backup copy.

10.3 New Vehicle Entry

To create customised vehicles and store them inside the database, you shall first of all display the page of the measurements and tolerances supplied by the manufacturer of an already-existing vehicle (see par. 8.3 on page 24).

Press “Ins” on the keyboard:



The following screen will be displayed:



Figure 64

As you can see in Figure 64 on the highlighted point, the make of the selected vehicle is highlighted by a red background.

You can enter or confirm the name of the make of the vehicle you want to create.

Then, select and enter:

- Vehicle model and submodel name
- Manufacturing start date
- Manufacturing end date
- Rim diameter
- Front track
- Rear track
- Left wheelbase
- Right wheelbase
- Load conditions
- Tank conditions

Use the following keys for data selection:

	Move selection to the following datum.
	Move selection to the previous datum.

After data entry, you can delete them using the following keys:

	It deletes the whole selected element
	It deletes the last character of the selected element

Once the manufacture end date has been entered and you move on the next datum, the following screen relating to load conditions will be displayed



Figure 65

After having selected rim diameter, the following data to be entered are vehicle track and wheelbase, in the following screen:











Figure 66





Then enter tank and load conditions
Now the screen will look as follows:



Figure 67

	SENS. KEYB.	PC KEYBOARD	DESCRIPTION
			It goes back to the introduction page. (see chap. 7 on page 18)
			It moves selection up.
			It moves selection down.

As can be seen from the enlargement on the right of Figure 67, it is necessary to specify whether the point to which the figure refers is adjustable or not.

	The point to which the data refer can be adjusted. To define it as not-adjustable, press:	
	The point to which the data refer cannot be adjusted. To define it as adjustable, press:	
Once the desired option has been selected, press:		



Once angle “adjustability” has been specified, you can enter the **graphic animations**.

Select the correct image or animation with keys  , then press “Enter” to confirm 

Now you shall enter vehicle standard tolerance values as for:

<p>FRONT AXLE:</p> <ul style="list-style-type: none"> • Toe • Camber • Caster • Kingpin • Included angle • Max. steering 	<p>REAR AXLE</p> <ul style="list-style-type: none"> • Toe • Camber • Thrust angle
--	--

Select data as described above, and enter values.

Warning: To separate whole values from decimals, try using a “dot”  or a “comma” .

When you have completed values entering, the following screen will be displayed. You will have to select an option:



Figure 68

Press F4  to confirm and create the customised vehicle.

If vehicle database is displayed, you can observe that also the just-created customised vehicle is present; it is listed under a separate make, in alphabetical order, written in italic.

Using the same procedure, you can edit the values of a customised vehicle without having to create a new one. The final screen will be like the one of Figure 68 with the additional item:

“Edit customised vehicle”

Select this option to edit vehicle data.

10.4 Customised Vehicle Deletion

You have to display vehicle database, and select the customised vehicle you wish to delete,

then press Ctrl + Canc:



Warning: If a customised vehicle is deleted, it will no longer be possible to restore it, unless you have a database backup copy.

11 PROGRAMME AND DATABASE PROTECTION SMART CARD

ART86TWS/TWSR and SPACE98TWS/TWSR all feature a PC with SMART CARD reader.

This SMART CARD, inserted inside reader, allows programme operation, and enables access to vehicle DATABASE

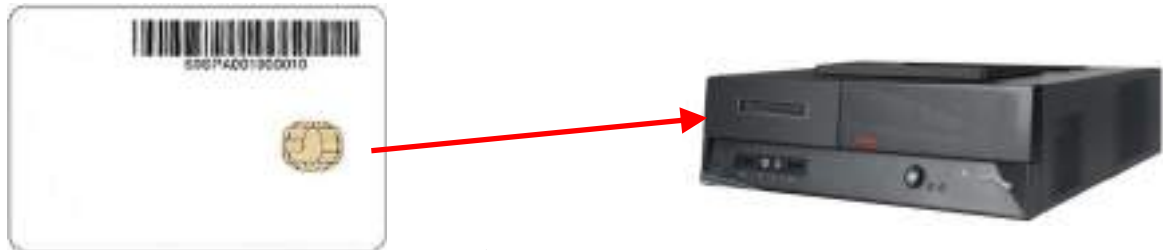

Figure 69

every machine has its own unique SMARTCARD that cannot be replaced with the SMARTCARD of another machine for whatever reason.

Should this SMARTCARD be removed or replaced, programme will display an error message, such as Figure 70, and will not give the authorisation to continue.



Figure 70

Database can be updated by downloading files from Internet.

Contact your retailer for further details on the download from the manufacturer's web site.

11.1 DATABASE Management

To update database, proceed as follows:

Select "Database Management" option from programme configuration menu (see chap.11.1) as specified in Figure 71, and press F4 to continue.





Figure 71

**Figure 72**

When a USB flash disk key is inserted (such as the one supplied with the machine, and containing system Back-Up), the keys for database management are displayed, as shown in Figure 73.

**Figure 73**

F2  → Export certificate on USB flash disk. Customer shall send it to the manufacturer so that a release key can be prepared (as an alternative to the communication of customer's SMARTCARD serial number).

F4  → It allows copying the correct path of the DATABASE file that has been previously downloaded from internet and inserted inside USB flash disk ROOT. Updated databases shall then be released through "Token" import.

F3  → Manufacturer sends the release code (called Token) to the customer after having checked the fulfilment of requirements (such as payment of the new Database). This "Token" file shall be pasted inside USB flash disk ROOT and, by selecting this key, Token is imported in the correct path on your own PC so that the new database is released.

12 DETECTORS' ERRORS

12.1 Data Reception/Transmission Error between Detectors and Cabin

During data transmission/reception between detectors and cabin, the following screen may be displayed:

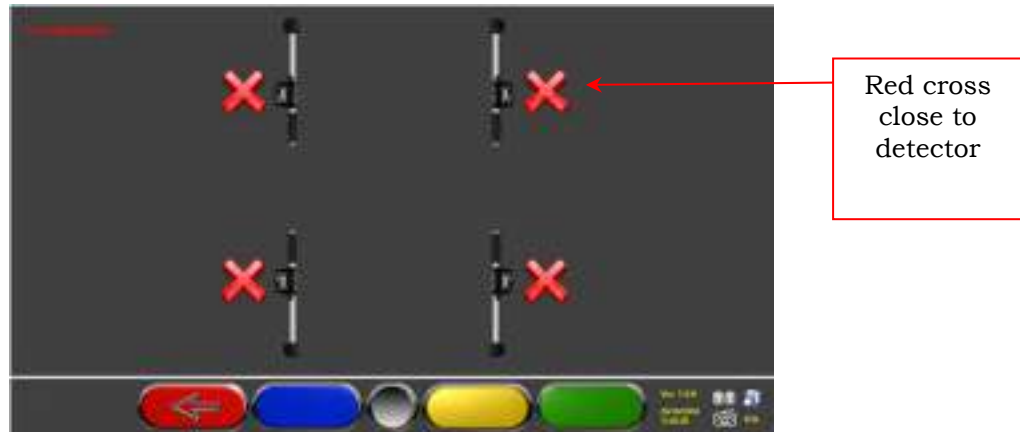

Figure 74

This means that there is a transmission/reception failure due to one or several of the following problems:

- Detectors infrared transceivers are not working
- There is a failure or a radio interference inside the transmission system,
- There is a hinder (ex. vehicle door open) between front and rear detectors.

Rear detectors do not directly communicate with cabin: their data are transmitted/received passing through front detectors so, if a front detector is not working properly, data could not be transmitted to the corresponding rear detector, even if this latter is working.

If the cause of failure is eliminated (ex. vehicle door is closed) error page will immediately disappear, and the measurement page will be displayed again. If the problem continues, check system hardware by switching machine off. Of course, it is not recommended to abruptly power cabin off; follow the correct switching off procedure:

- Press “Esc” on keyboard to go back to the introduction page (chap.7 on page18).
- Switch machine off following the correct procedure (see par.4.2 on page 15).

12.2 Angle Measurement Horizontal Error

The following screens may be displayed during infrared data measurement:

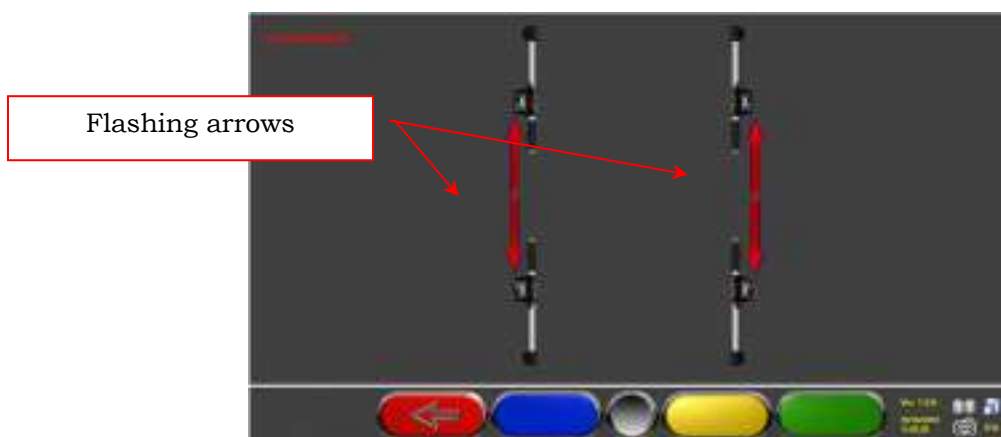

Figure 75

This error page indicates that one or more horizontal infrared measurements cannot be carried out.

There may be several causes:

- One or more CCD sensors (digital infrared transducer for horizontal angle measurement) are not working.
- One or more infrared emitters for horizontal angle measurement (I.R. LED) are not working.
- There is a hinder (ex. vehicle door open) between front and rear detectors.

If the cause of failure is eliminated (ex. vehicle door is closed) error page will immediately disappear, and the measurement page will be displayed again. If the problem continues, check system hardware by switching machine off. Of course, it is not recommended to abruptly power cabin off; follow the correct switching off procedure:

- Press “Esc” on keyboard to go back to the introduction page (see chap. 7 on page 18).
- Switch machine off following the correct procedure (see par.4.2 on page 15).

13 TROUBLES

Some of the most common problems that could arise on wheel aligners are listed here below. s.r.l. declines all liability for injury or damage to persons, animals and properties caused by the intervention of unauthorised personnel, and by the use of non-original spare parts.

Before doing any operation on the system, always disconnect the power supply.

In case of doubt, do not interpret, but contact s.r.l. technical assistance in order to obtain instructions suitable for performing operations in total safety.

TROUBLE	CAUSE	REMEDY
NO OPERATION	- No mains voltage - Interrupted protection fuses	- Check mains voltage - Check protection fuses
Monitor does not work	- No supply voltage - No video signal	- Check power cable connection - Check video signal cable connection between PC and monitor
PC cannot be switched on	- No supply voltage	- Check PC ON/OFF switch - Check power cable connection
Printer does not work (see also printer user's manual)	- No supply voltage - No signal	- Check ON/OFF voltage - Check power cable connection - Check printer signal cable connection with PC

14 MAINTENANCE

WARNING! Before doing any maintenance job, the machine will have to be disconnected from the power mains.

To clean plastic panels or surfaces use alcohol (AVOID USING LIQUIDS CONTAINING SOLVENTS).

DISPLAY shall be cleaned with a dry cloth; if very dirty, clean it with a moist cloth, then dry it.

Do not spray the alcohol directly on the control panel and do not clean using strong jets of compressed air.

Keep optical unit methacrylate filters clean using a slightly moist cloth, do not use solvents;

Printer cleaning, cartridge replacement and any other maintenance operation on printer are described in the manual supplied with the printer itself. Always refer to this manual before carrying out any maintenance operation on printer.

15 STORAGE AND SCRAPPING

Storage - If the machine has to be stored for a long period of time, disconnect all supply lines and protect the display screen, which could be damaged by excessive dust. Grease any parts liable to be damaged by dryness.

Scrapping - If the machine is to be no longer used, it must be made inoperative: All those parts that could represent a potential hazard risk must be correctly disposed of. Dispose of parts according to category. Scrap as iron scrap through authorised channels. Parts considered as special waste must be removed and split up according to type and then disposed of through authorised channels according to applicable regulations.



In order to inform the users regarding the correct disposal of batteries and accumulators, please take note of the following: the meaning of the symbol with the crossed-out wheeled bin marked on the accumulator is that the product cannot be disposed of in municipal solid waste (i.e. together with "mixed waste").

It must be handled separately with the purpose of performing specific operations for its reuse or treatments for eliminating and disposing safely of any substances that could be dangerous for the environment and extract and recycle the raw materials that may be reused. For further detailed information on the end-of-life treatment of batteries and accumulators, please contact the After-sales department of s.r.l..

16 MACHINE IDENTIFICATION DATA

		MODEL ARP 99 WS		SERIAL N°	
		VOLTAGE 220V		WEIGHT 100kg	

A) Manufacturer
 B) Model
 C) Machine weight
 D) Serial number
 E) Year of manufacture

WARNING: It is strictly forbidden to tamper with, notch, somehow alter or even remove machine identification plate; do not cover it with temporary panels, etc... as it shall always be clearly visible.

Said plate must always be kept clean.

CAUTION: Should the plate be accidentally damaged (removed from the machine damaged or even partially illegible) inform immediately the manufacturer.



Informazione agli utenti

ai sensi dell'art. 13 del Decreto legislativo 25 Luglio 2005, n. 151 "Attuazione delle Direttive 2002/95/CE, 2002/96/CE e 2003/108/CE, relative alla riduzione dell'uso di sostanze pericolose nelle apparecchiature elettriche ed elettroniche, nonché allo smaltimento dei rifiuti"

Il simbolo del cassonetto barrato riportato sull'apparecchiatura o sulla sua confezione indica che il prodotto alla fine della propria vita utile deve essere raccolto separatamente dagli altri rifiuti.

La raccolta differenziata della presente apparecchiatura giunta a fine vita è organizzata e gestita dal produttore. L'utente che vorrà disfarsi della presente apparecchiatura dovrà quindi contattare il produttore e seguire il sistema che questo ha adottato per consentire la raccolta separata dell'apparecchiatura giunta a fine vita.

L'adeguata raccolta differenziata per l'avvio successivo dell'apparecchiatura dismessa al riciclaggio, al trattamento e allo smaltimento ambientalmente compatibile contribuisce ad evitare possibili effetti negativi sull'ambiente e sulla salute e favorisce il reimpiego e/o riciclo dei materiali di cui è composta l'apparecchiatura.

Lo smaltimento abusivo del prodotto da parte del detentore comporta l'applicazione delle sanzioni amministrative previste dalla normativa vigente.

English

Disposal of Waste Electrical & Electronic Equipment (Applicable in the European Union only)

The symbol (crossed out wheeled-bin) on your product indicates that the product shall not be mixed or disposed with your household waste, at their end of use.

This product shall be handed over to your local community waste collection point for the recycling of the product.

For more information, please contact your Government Waste-Disposal department in your country. Inappropriate waste handling could possibly have a negative effect on the environment and human health due to potential hazardous substances. With your cooperation in the correct disposal of this product, you contribute to reuse, recycle and recover the product and our environment will be protected.

For further information please contact your dealer or distributor in your country. This product shall not be mixed or disposed with commercial waste.

Français

Traitement des appareils électriques et électroniques en fin de vie (Applicable dans les pays de l'Union Européenne seulement)

Ce symbole (poubelle interdite) apposé sur le produit indique qu'en fin de vie ce produit ne doit pas être traité avec les déchets ménagers.

Il doit être remis à un point de collecte approprié pour le recyclage des appareils électriques et électroniques.

Pour de plus amples informations, veuillez contacter le service de collecte des déchets ménagers local. Ce produit contient des substances potentiellement dangereuses qui peuvent avoir des effets néfastes sur l'environnement et la santé humaine. En veillant à la mise au rebut correcte de ce produit, vous contribuez à assurer le traitement, la récupération et le recyclage de ce produit et à protéger l'environnement.

Pour de plus amples informations veuillez contacter votre revendeur ou distributeur local. Ce produit ne doit pas être traité avec les déchets d'entreprises.

Espanol

Disposicion sobre Residuos de aparatos eléctricos y electronicos (Aplicable solo a la Union Europea)

Los productos identificados con este simbolo (papelera tachada) no deben eliminarse como residuos domésticos una vez finalizada su vida útil.

Este producto debe entregarse a un punto de recogida de la comunidad local para su recuperacion y reciclado.

Para mayor informacion, sirvase ponerse en contacto con el Departamento de Disposicion de Desechos de su Ayuntamiento. El manejo inadecuado de los residuos supone riesgos para la salud humana o el medio ambiente. Con la reutilizacion, el reciclado de los materiales u otras formas de valorizacion de tales productos usted contribuye de manera importante a la proteccion de nuestro medio ambiente.

Para mayor informacion sirvase ponerse en contacto con el concesionario o distribuidor de su pais. Este producto no deber mezclarse ni desecharse junto con los residuos comerciales.

Deutsch

Entsorgung von elektrischen & elektronischen Produkten (Anzuwenden nur in den Ländern der Europäischen Union)

Dieses Symbol (ausgekennzeichnete Mülltonne) auf dem Produkt bezeichnet, dass Altgeräte usw. nicht wie normaler Haushaltsabfall in den Müll gegeben werden dürfen, sondern zum Recycling an einer hierfür vorgesehenen Annahmestelle abzugeben ist.

Für nähere Informationen wenden Sie sich bitte an die für Müllentsorgung zuständigen örtlichen Behörden. Bei unsachgemäßer Entsorgung besteht das Risiko nachteiliger Auswirkungen auf Umwelt und Gesundheit durch potentiell gefährliche Substanzen. Durch Ihre Kooperation zur ordnungsgemäßen Entsorgung fördern Sie die Wiederverwendung, das Recycling und die Rückgewinnung von Stoffen und tragen zum Umweltschutz bei.

Für nähere Informationen wenden Sie sich bitte an Ihren Händler oder den zuständigen Vertrieb. Das Produkt darf nicht in den normalen Gewerbemüll gegeben werden.



**Dichiarazione di Conformità CE
EU-Declaration of Conformity
Déclaration CE de conformité
EU Konformitätserklärung
Declaración de Conformidad CE**

**FASEP 2000 srl
Via Faentina 96
50032 Ronta (Fi), Italy.**

-dichiara, sotto esclusiva responsabilità, che il sottoindicato prodotto é conforme alle direttive e norme indicate:
-declare, under own responsibility, that the below indicated equipment complies with the following norms and directives:
-déclare, sous propre responsabilité, que l'équipement ci-dessous indiqué est conforme au normes et directives:
-erklärt unter eigener Verantwortung, dass die unten bezeichnete Ausrüstung mit folgenden Normen und Richtlinien übereinstimmt:
-declara, bajo exclusiva responsabilidad, que el producto abajo indicado es conforme a las normas y las directrices indicadas:

Tipo di prodotto / Type of equipment: assetti ruote / wheel aligners
Modello, Nr di serie / Model, Serial nr.: vedi targhetta / see badge

Direttive applicate / Applied CE-Directives

Bassa Tensione / Low Voltage Directive: **2014/35/UE**

Compatibilità Elettromagnetica / Electromagnetic Compatibility Directive: **2014/30/UE**

Norme Armonizzate applicate / Applied Harmonised Standards

EN 60204-1:2018, BS EN IEC 61000-6-1:2019, BS EN IEC 61000-6-3:2021

Ronta, Firenze

Data _____

FASEP 2000 srl
Fulvio Boni, Presidente

Persona autorizzata a costituire il Fascicolo Tecnico:
Fasep 2000 srl, Via Faentina 96 - Ronta, 50032 Borgo San Lorenzo (Fi)



**Dichiarazione
Declaration**

**FASEP 2000 srl
Via Faentina 96
50032 Ronta (Fi), Italy.**

-dichiara, sotto esclusiva responsabilità, che il sottoindicato prodotto é conforme alle direttive e norme indicate:
-declare, under own responsibility, that the below indicated equipment complies with the following norms and directives:

Tipo di prodotto / Type of equipment: assetti ruote / wheel aligners
Modello, Nr di serie / Model, Serial nr.: vedi targhetta / see badge

UK Regulations

Bassa Tensione / Low Voltage Directive:
Electrical Equipment (Safety) Regulations 2016

Compatibilità Elettromagnetica / Electromagnetic Compatibility Directive:
Electromagnetic Compatibility Regulations 2016

UK Designated Standards (with the prefix BS)

**BS EN 60204-1:2018
BS EN IEC 61000-6-3:2021
BS EN IEC 61000-6-1:2019**

Ronta, Firenze

Data _____

FASEP 2000 srl
Fulvio Boni, Presidente

Persona autorizzata a costituire il Fascicolo Tecnico:
Fasep 2000 srl, Via Faentina 96 - Ronta, 50032 Borgo San Lorenzo (Fi)