

Copyright Information

Copyright © 2019 by LAUNCH TECH. CO., LTD. All rights reserved. No part of this publication may be reproduced, stored in a retrieval system, or transmitted in any form or by any means, electronic, mechanical, photocopying, recording or otherwise, without the prior written permission of LAUNCH.

Neither LAUNCH nor its affiliates shall be liable to the purchaser of this unit or third parties for damages, losses, costs, or expenses incurred by purchaser or third parties as a result of: Accident, misuse, or abuse of this unit, or unauthorized modifications, repairs, or alterations to this unit, or failure to strictly comply with LAUNCH operating and maintenance instructions. LAUNCH shall not be liable for any damages or problems arising from the use of any options or any consumable products other than those designated as Original LAUNCH Products or LAUNCH Approved Products by LAUNCH.

All information, specifications and illustrations in this manual are based on the latest information available at the time of printing. LAUNCH reserves the right to make changes at any time without prior written or oral notice.

Trademark Information

LAUNCH is a registered trademark of LAUNCH TECH CO., LTD. (LAUNCH) in China and other countries. All other LAUNCH trademarks, service marks, domain names, logos, and company names referred to in this manual are either trademarks, registered trademarks, service marks, domain names, logos, company names of or are otherwise the property of LAUNCH or its affiliates. In countries where any of the LAUNCH trademarks, service marks, domain names, logos and company names are not registered, LAUNCH claims other rights associated with unregistered trademarks, service marks, domain names, logos, and company names. Other products or company names referred to in this manual may be trademarks of their respective owners. You may not use any trademark, service mark, domain name, logo, or company name of LAUNCH or any third party without permission from the owner of the applicable trademark, service mark, domain name, logo, or company name. You may contact LAUNCH by visiting the website at www.cnlaunch.com, or writing to LAUNCH TECH. CO., LTD., Launch Industrial Park, North of Wuhe Avenue, Banxuegang, Bantian, Longgang, Shenzhen, Guangdong, P.R.China, to request written permission to use Materials on this manual for purposes or for all other questions relating to this manual.

Table of Contents

1 Safety Precautions	1
2 Product Description	3
2.1 Profile	3
2.2 Packing List	3
3 Knowledge of X-431 ADAS PRO Calibration Tool.....	6
3.1 X-431 ADAS PRO Calibration Tool	6
3.2 Base Support	8
3.3 Beam Lifter (Upstand)	9
3.4 Calibration Frame & Cross Memeber	11
3.5 Laser Module	13
3.5.1 Installing the batteries	13
3.5.2 Adjusting the laser beam spot size	14
3.6 3 Points Wheel Alignment Clamp.....	14
3.6.1 Installing the attachment bracket on the wheel clamp.....	16
3.6.2 Installing the laser module on the wheel clamp	16
3.6.3 Attaching the wheel clamp to the vehicle's tyre	17
3.7 Radar Kit	18
3.8 Laser Range Finder.....	19
3.8.1 Installing the battery	19
3.8.2 Operation tips.....	19
4 Initial Use	21
4.1 Installing the ADAS Calibration Tool	21
4.1.1 Installing the beam lifter on the base support.....	21
4.1.2 Installing the cross member & calibration frame.....	22
4.1.3 Installing the radar kit	26
4.1.4 Installing the calibratioin reference pattern	26
4.2 Activate the Software Calibration Function	27
5 Working with the ADAS Calibration Tool.....	30
5.1 Precondition for the Use of the ADAS Calibration Tool	30
5.2 Calibrating Camera-based ADAS	33
5.2.1 Calibrating the front camera	33

5.2.2 Calibrating the rear camera.....	40
5.3 Calibrating Radar-based ADAS.....	42
5.3.1 Calibrating the radar sensor with magnetic laser	43
5.3.2 Calibrating the radar sensor without magnetic laser	43
6 Care & Maintenance	45
Appendix: Car ADAS Reference Pattern Kit.....	46

1 Safety Precautions

The X-431 ADAS PRO calibration tool is exclusively intended for use on a vehicle. To avoid personal injury, property damage, or accidental damage to the product, read all of the information in this section before using the product:

- To operate the X-431 ADAS PRO calibration tool properly, user must have knowledge of automotive technology and is therefore aware of the sources of danger and risks in the repair shop and on vehicles.
- All notes given in the individual sections of the operating instructions apply. In principle it is required to follow the steps and safety precautions stated below.
- Furthermore, pay attention to all general instructions from labor inspectorates, trade associations and vehicle manufacturers as well as all laws, legal ordinances and instructions which have to be commonly obeyed by a repair shop.

The safety messages herein cover situations LAUNCH is aware of. LAUNCH cannot know, evaluate or advise you as to all of the possible hazards. You must be certain that any conditions or service procedure encountered do not jeopardize your personal safety.

On Using X-431 ADAS PRO Calibration Tool

In order to avoid incorrect handling and injury to the user or destruction of the X-431 ADAS PRO calibration tool arising from this, pay attention to the following:

- Only assemble the X-431 ADAS PRO calibration tool according to the operating instructions.
- Protect the X-431 ADAS PRO calibration tool from water and strong impacts.
- Protect the X-431 ADAS PRO calibration tool from long periods of exposure to solar radiation.
- Do a regular check and service for the X-431 ADAS PRO calibration tool.

On Using Vehicle

When working on the vehicle, please carefully read the following information:

- Put blocks in front of the driver wheels to protect vehicle against rolling away.
- The park position should also be engaged in automatic vehicles.
- Always attach the protective cylinder set to the rim flange or tyre to prevent it from scratching surfaces or damage to wheel rims.
- After a calibration is completely performed, remember to unplug the VCI device

from the vehicle's diagnostic socket.

On Using Laser Module

There is a risk of injury through dazzling the eyes when working with the laser.

Therefore regard the following:

- Do not direct the laser beam towards persons, doors or windows.
- Never look directly into the laser beam because it may cause damage to/destruction of the retina.
- Ensure the calibration room is properly illuminated.
- While moving the laser module, hold it tightly to protect it from falling down on the floor.
- While installing a laser module, please make sure it is firmly and securely attached.
- Only use a straight screwdriver to adjust the laser beam radius.

2 Product Description

2.1 Profile

Advanced Driver Assistance Systems (ADAS) are electronic components in vehicles, which include a wide range of safety features for vehicles such as autonomous emergency braking (AEB), lane departure warning (LDW), lane keep assist, blind spot elimination, night vision cameras and adaptive lighting.

Initially only found on premium segment, the number of modern mid-class and compact vehicles equipped with Advanced Driver Assist Systems is growing at a rapid rate.

The cameras and sensors used by these systems have to be precisely calibrated and adjusted. Incorrect calibration resulting from windscreen replacement or wheel alignment can cause the system to deliver incorrect results or even fail completely, resulting in a serious accident or even a fatality.



In light of this, Launch has developed the X-431 ADAS PRO calibration tool. As a comprehensive and flexible calibration tool, it enables you to effectively and accurately calibrate a wide range of camera-based & radar-based driver assistance systems, e.g. the front camera for the lane departure warning system, the radar sensor for the ACC (Adaptive Cruise Control) or the camera for adaptive headlights. Repair and service shops do not require a fully equipped wheel alignment station or a leveled workshop ground or platform lift in order to work with X-431 ADAS PRO calibration tool. There are two main components to the X-431 ADAS PRO calibration tool:



- Calibration Tool – It is designed to calibrate the position of the vehicle sensor and target. It mainly consists of calibration frame (calibration panel available in packages or individual), cross member, wheel clamp, laser module and radar kit etc.
- Diagnostic Tool (sold separately) – The calibration tool can be exclusively operated in conjunction with a Launch's diagnostic tool. Diagnostic tools from other manufacturers will not be supported.

2.2 Packing List

Please check the packing list upon receiving your tool so that complaints can be issued immediately regarding potential damage or missing parts. For different destinations, the accessories may vary. For details, please consult from the local dealers or check the included packing list.

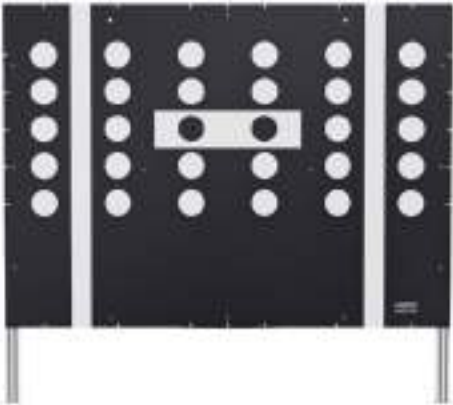
*While unloading, please note:
The heavy tool may drop down and cause injuries, remember to always unload the tool with the aid of a second person or use suitable aid as necessary.

Items	Pictures	Qt.
Base support kit		1
Beam lifter kit		1
Cross member kit		1
Calibration panel kit	 <p>(*Note: Different vehicle makes has different calibration reference patterns. This item is available as in packages or individual.)</p>	(Optional)

Wheel clamps kit		2
Radar kit		1
User manual		1
Power adaptor	To provide power to the beam lifter through connection to AC outlet.	1
ADAS Activation Card (optional)	The ADAS calibration software on the diagnostic tool is disabled at default. User needs to activate it using the included activation card first before performing the calibration function.	1
Laser range finder	A range finder determines the distance to an object using a laser beam.	1

3 Knowledge of X-431 ADAS PRO Calibration Tool

3.1 X-431 ADAS PRO Calibration Tool

The X-431 ADAS PRO calibration tool mainly includes the following items and components:

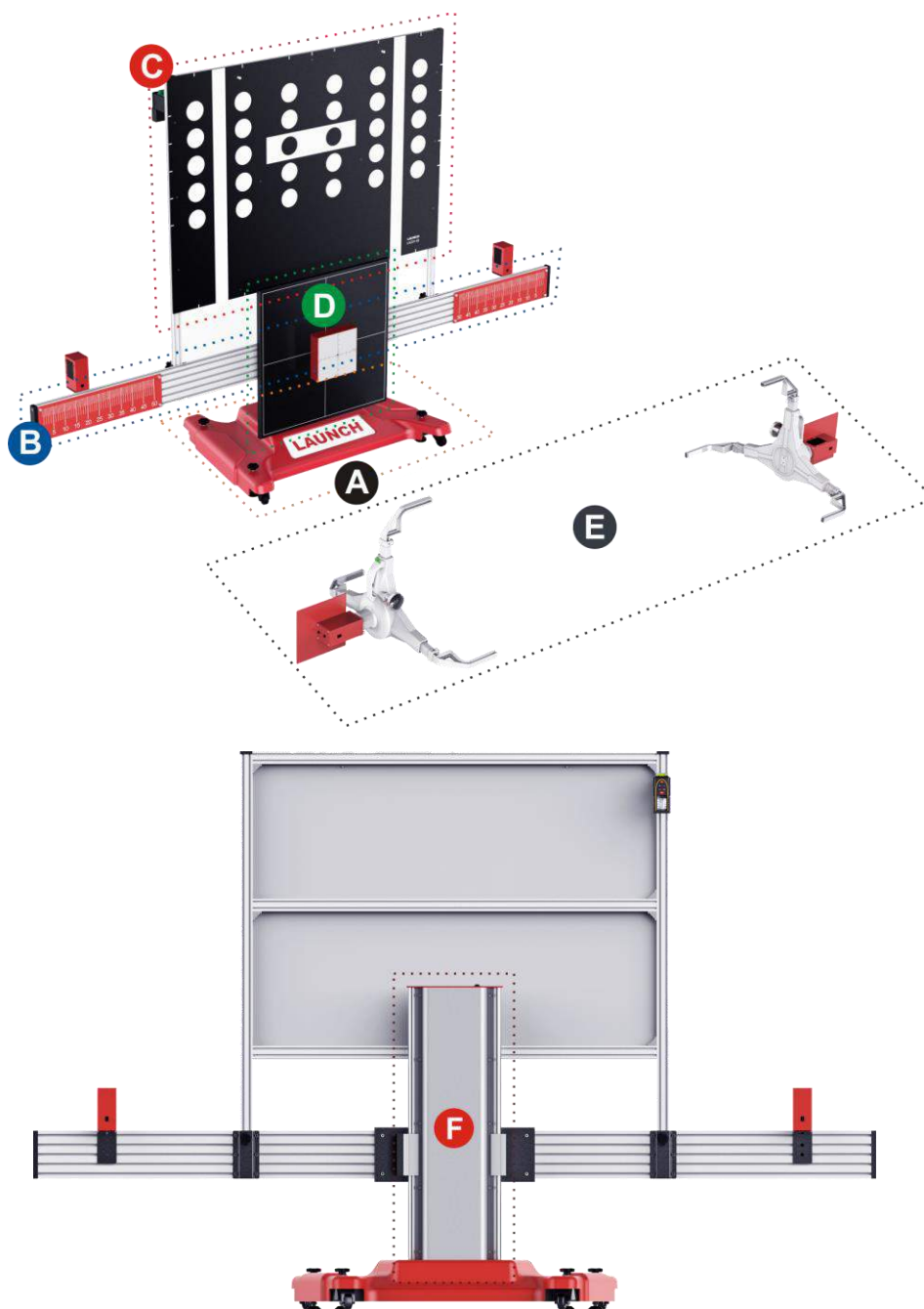

Fig. 3-1 (This figure is fictitious and only for illustrative purpose. It is subject to change due to

product improvements)

No.	Description
A	<p>Base support</p> <p>To firmly fasten the beam lifter to balance the cross member and calibration frame installed on the lifter. Equipped with four rolling casters, it also provides the ability to move the tool anytime and anywhere.</p> <p><i>See Chapter 3.2 for details.</i></p>
B	<p>Cross member</p> <p>It is installed on the beam lifter and supports the calibration frame. To obtain more accurate result, ensure the cross member is centrally mounted on the the beam lifter.</p> <p><i>See Chapter 3.4 for details.</i></p>
C	<p>Calibration frame</p> <p>Here you will need different calibration patterns depending on the car manufacturer. These are optionally available.</p> <p><i>See Chapter 3.4 for details.</i></p>
D	<p>Radar kit</p> <p>There are three main components to the standard radar kit: radar reflector, magnetic laser and attachment bracket. A corner reflector (<i>See Appendix</i>) is also required if necessary.</p> <p><i>See Chapter 3.7 for details.</i></p> <p>*Note: Radar kit is required only when calibrating Radar-based ADAS.</p>
E	<p>3 Points Wheel Alignment clamp</p> <p>It can be adjusted to best fit with the vehicle's tyre. A laser module so that the vehicle is placed centred in front/rear of and in parallel with the calibration tool.</p> <p><i>See Chapter 3.6 for details.</i></p>
F	<p>Beam lifter</p> <p>Connected to the AC outlet, it sits in the center of the base support and controls the height of the calibration frame. A scale ruler is also available on it for reading the height of the calibration frame.</p> <p><i>See Chapter 3.3 for details.</i></p>

3.2 Base Support

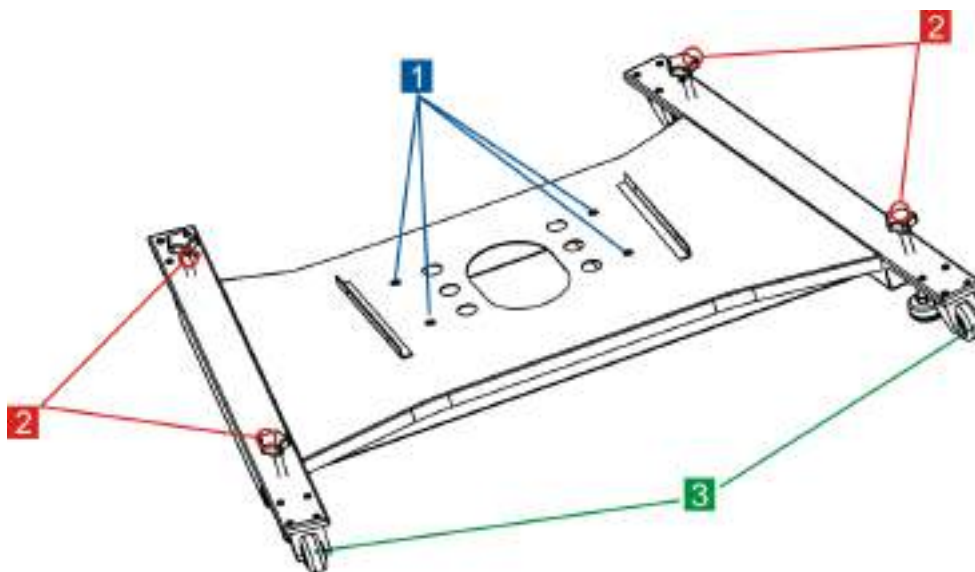

Fig. 3-2

No.	Description
1	Mouting hole For securing the beam lifter.
2	Adjustment screws Use the adjustment screws to balance the level gauge of the base support.
3	Rolling caster Allows you to move the tool from one place to another place.

3.3 Beam Lifter (Upstand)

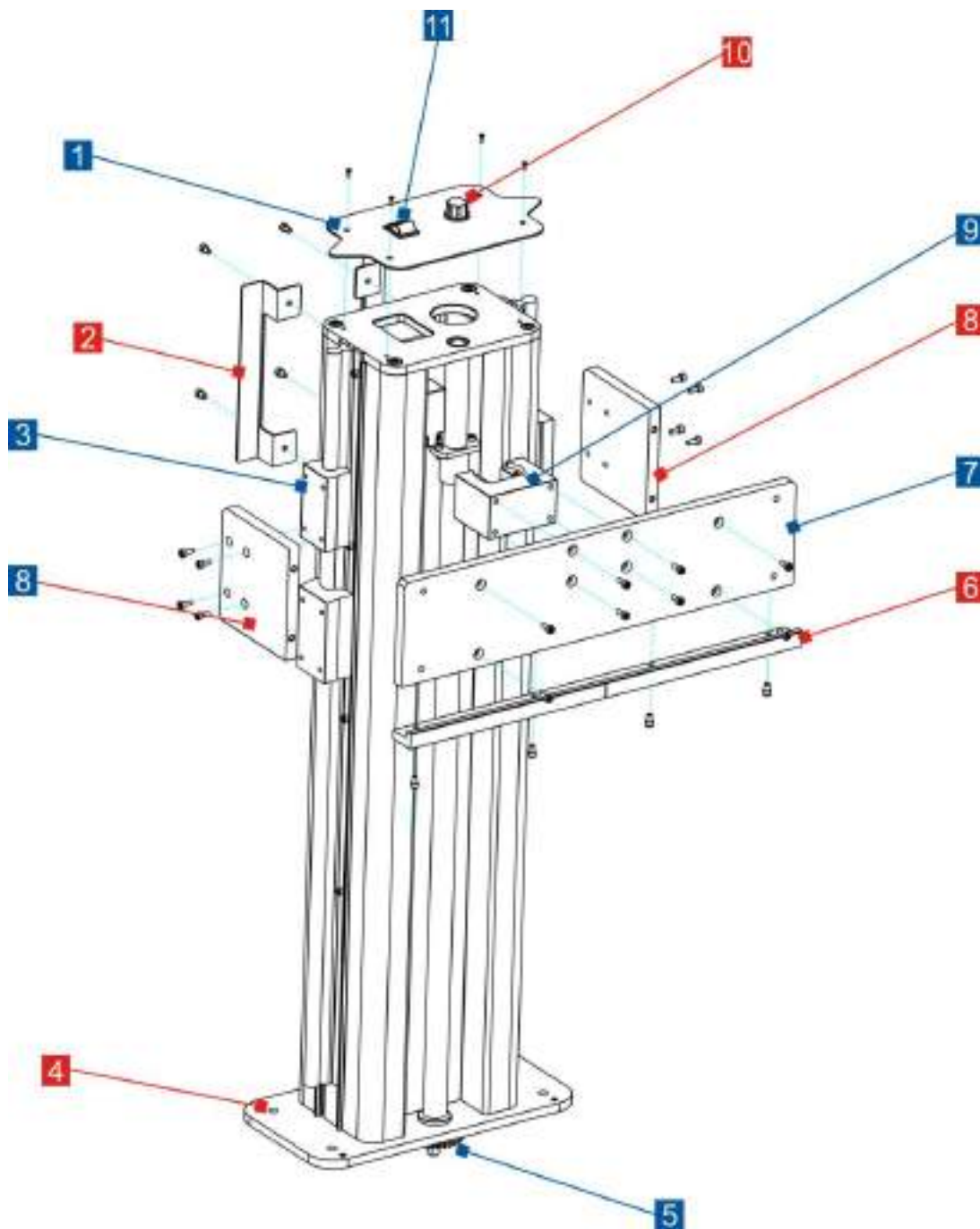

Fig. 3-3

No.	Description
1	<p>Upper cover</p> <p>It should be removed firstly before disassembling and installing all other components of the beam lifter. A rocker switch (11) and a tuning knob (10)</p>

	are available on it.
2	Handle For moving and holding the beam lifter easier.
3	Slider For lifting the cross member up or dropping it along the lifter. <u>Note: There are two sliders pre-installed on each guide rail. To prevent the beam lifter from shaking, you are strongly suggested to use the cross-linking bracket 3 to lock the sliders at the same time.</u>
4	Mouting holes
5	Bearing Never collide it abruptly when installing the beam lifter. Doing so may cause damage to it.
6	Cross-linking bracket 1
7	Cross-linking bracket 2
8	Cross-linking bracket 3 A scale indicator is installed on the bracket for indicating the scale on the beam lifter.
9	Feed screw nut
10	Tuning knob Controls the ascending/descending speed of the slider (3).
11	Rocker switch It has total 3 control levels: Up, Stop and Down.

3.4 Calibration Frame & Cross Memeber

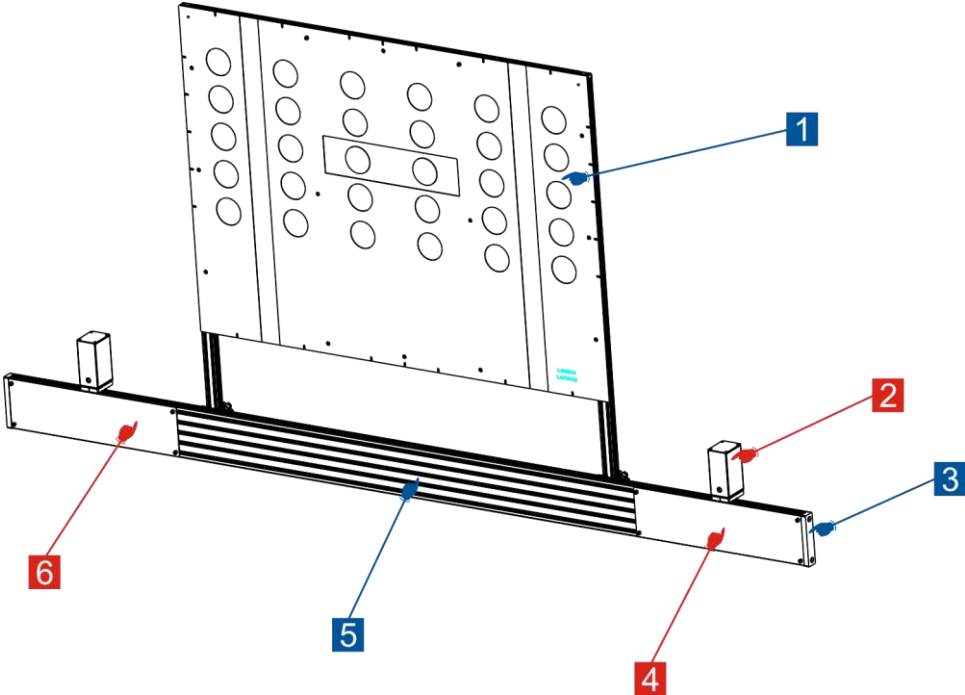

Fig. 3-4a Front view

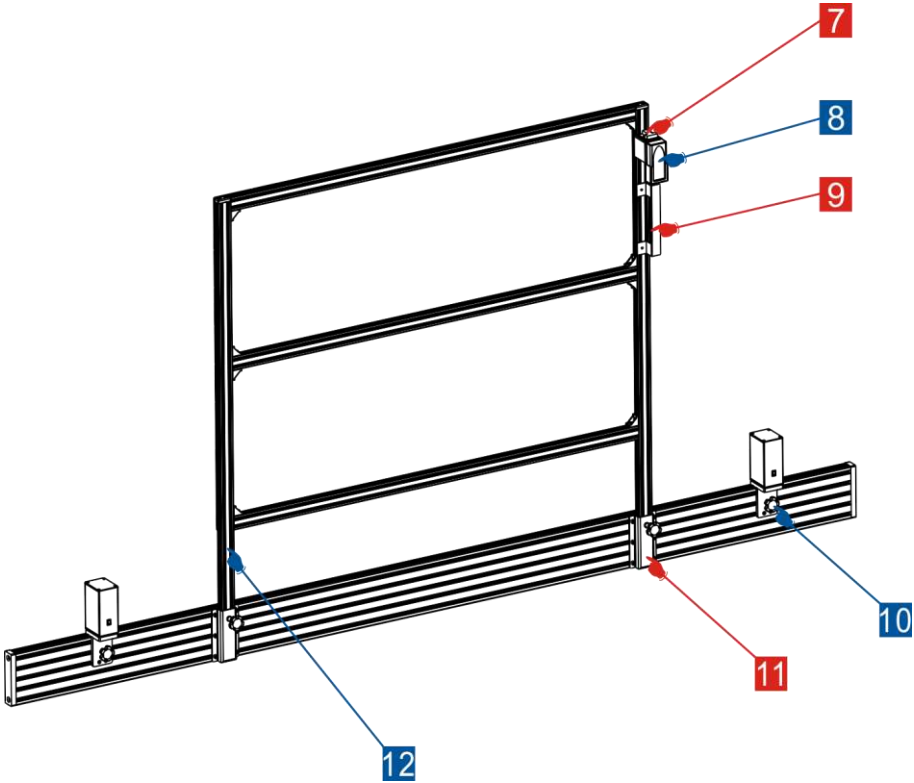

Fig. 3-4b Rear view

No.	Description
1	<p>Calibration pattern</p> <p>The pattern varies from vehicle to vehicle. The default calibration pattern is VAG Type 1(Front).</p> <p><i>For detailed calibration reference patterns, please refer to Appendix.</i></p>
2	<p>Laser module</p> <p>The actual value can be projected onto the scale of the 3 points wheel alignment clamp with the help of the laser.</p> <p><i>For details on the laser module, see Chapter 3.6.</i></p> <p>*Note: This laser module features the same functions as that installed on the wheel clamp.</p>
3	<p>Cover of cross member</p> <p>All items mounted on the cross member be installed before closing the covers on the cross member.</p>
4	Right scale
5	Cross member
6	Left scale
7	Level gauge
8	Laser range finder
9	Handle
10	<p>Laser module holder</p> <p>For supporting and fixing the laser module.</p> <p>*Note: To obtain accurate calibration result, please make sure that the laser modules are evenly distributed and installed on the both ends of the cross member.</p>
11	Fixed bracket for calibration frame
12	Calibration frame

3.5 Laser Module

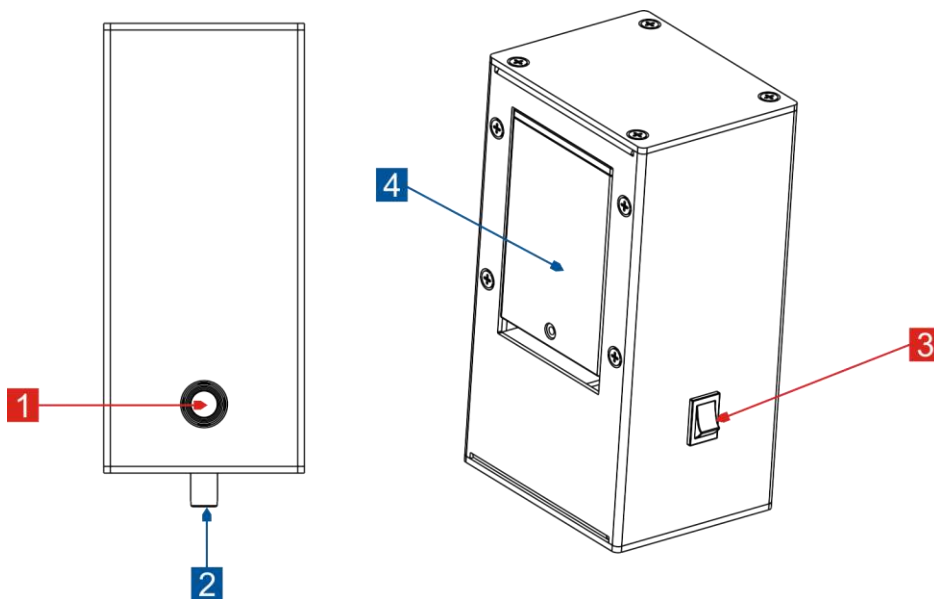

Fig. 3-5

No.	Description
1	Output of the laser beam Output for laser beam. Use the laser beam to read the actual value at the scales of the cross member and at wheel clamp.
2	Mounting bolt Use this to secure the laser module on the cross member.
3	Switch Switch the laser on and off.
4	Battery compartment cover 3 type AA batteries can be inserted into the battery compartment.

3.5.1 Installing the batteries

Proceed as follows to replace the batteries:

1. Switch off the laser beam (1) with the switch (3).
2. Loosen the screw of the battery compartment cover (4), and then push it along the indicator to remove it.



Fig. 3-6

3. Follow the correct installation direction/battery polarities to install the new batteries.
4. Restore the battery compartment cover and use the screw to fasten it.

3.5.2 Adjusting the laser beam spot size

Proceed as follows to to adjust the the radius of laser beam:

1. Switch on the laser beam (1) with the switch (3).
2. Use the straight screwdriver (not included) to adjust the laser beam radius as desired.

*Caution: Laser radiation may cause damage to/destruction of the retina. Never look directly into the laser beam.

*Note: To avoid the intuitive distinction, you are suggested to keep the beam radius of the laser modules as same as possible.

3.6 3 Points Wheel Alignment Clamp

Total 2 wheel clamps (left & right) are available for the wheel clamp. While attaching it onto the vehicle's tyre, please pay attention to the installation direction.

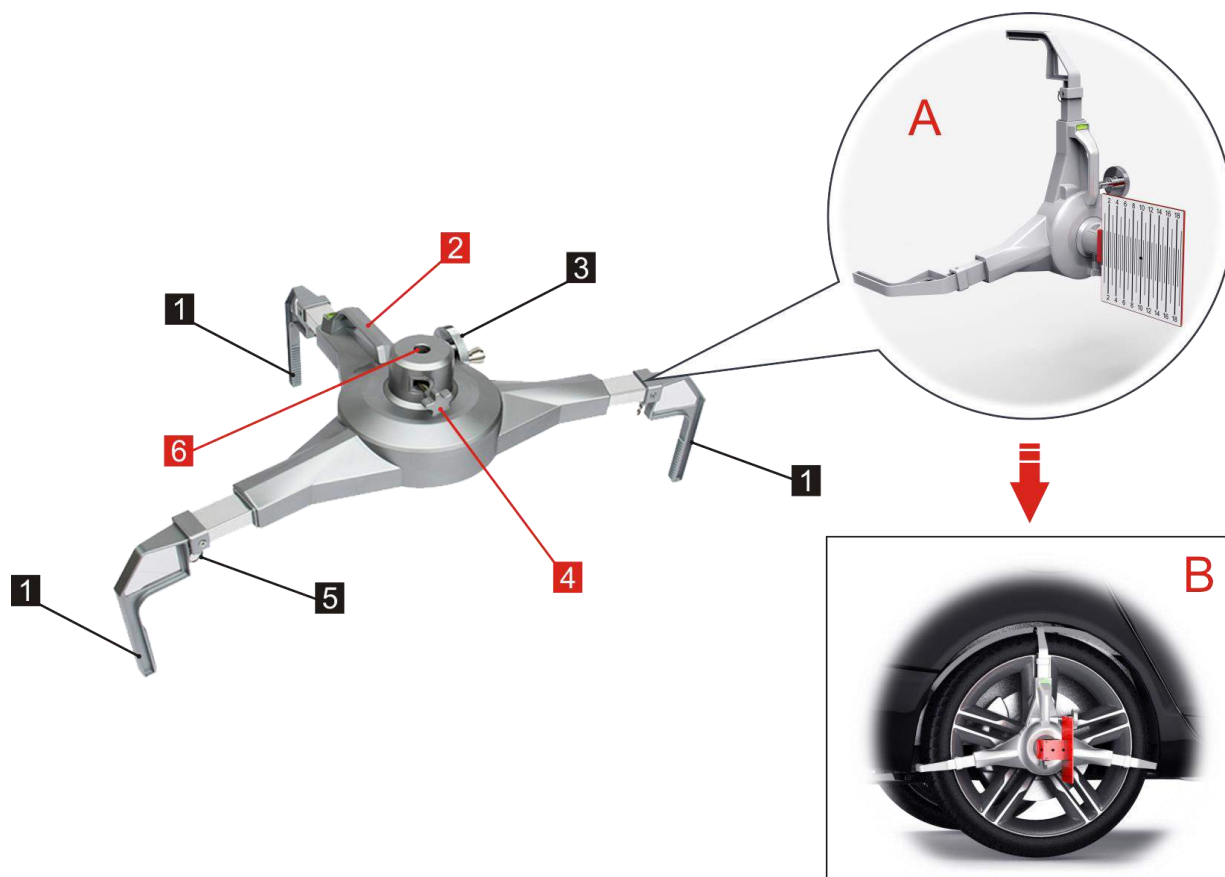

Fig. 3-7

No.	Description
1	Attachment brackets for vehicle tyre Attach it to the vehicle's tyre.
2	Handle
3	Adjustment screw Turning it can slide all attachment brackets (1) in (out) simultaneously.
4	Set screw To fasten/loosen the laser module.
5	Cable pull switch Use the finger to pull it, the attachment bracket (1) can be adjusted to different position or detached from the wheel clamp.
6	Mounting slot for laser module

3.6.1 Installing the attachment bracket on the wheel clamp

1. Take out the attachment brackets from the package box.
2. Follow the instructions in Fig. 3-8 to insert the attachment brackets into the wheel clamp respectively, ensuring the left and right attachment brackets are installed into the same depth.

*Note: To insert the attachment brackets to the bottom of the slot, just pull the cable pull switch and then push it until it reaches to the bottom.



Fig. 3-8

3. After properly installing, hold the handle of the wheel clamp and store it, making sure that the attachment brackets firmly sit on the ground.

3.6.2 Installing the laser module on the wheel clamp

If the laser module is ON, the actual value can be projected onto the scale of the cross member with the help of the laser beam.

*Note: This laser module features the same functions as that installed on the cross member. It is integrated with the scale of the wheel clamp.

1. Loosen the set screw (4).
2. Align one end of the exclusive laser module with the mounting slot of the wheel clamp, and then insert it into the mounting slot, making sure that the battery compartment cover side facing down. See Fig. 3-7A.
3. Use the set screw (4) to tighten it and follow Fig. 3-9a to lay it aside.



Fig. 3-9a (Correct)



Fig. 3-9b (Wrong)

*Note: Prevent the laser module on the wheel clamp from contacting with the ground when storing the wheel clamp. See Fig. 3-8b. Doing so may destroy the installation of the laser module and cause calibration error.

3.6.3 Attaching the wheel clamp to the vehicle's tyre

After properly installing the wheel clamp, you need to attach the wheel clamp to the vehicle's tyre.

1. Hold the handle to install the wheel clamp on the tyre. Use the adjustment screw to slowly slide out the turning rod until it fits the tyre's size and the level gauge bubble is centred.
2. Tighten the adjustment screw so that the wheel clamp can gently attach on the vehicle's tyre. See Fig. 3-7B.

3.7 Radar Kit

There are three main components to the radar kit: radar reflector, magnetic laser and attachment bracket.

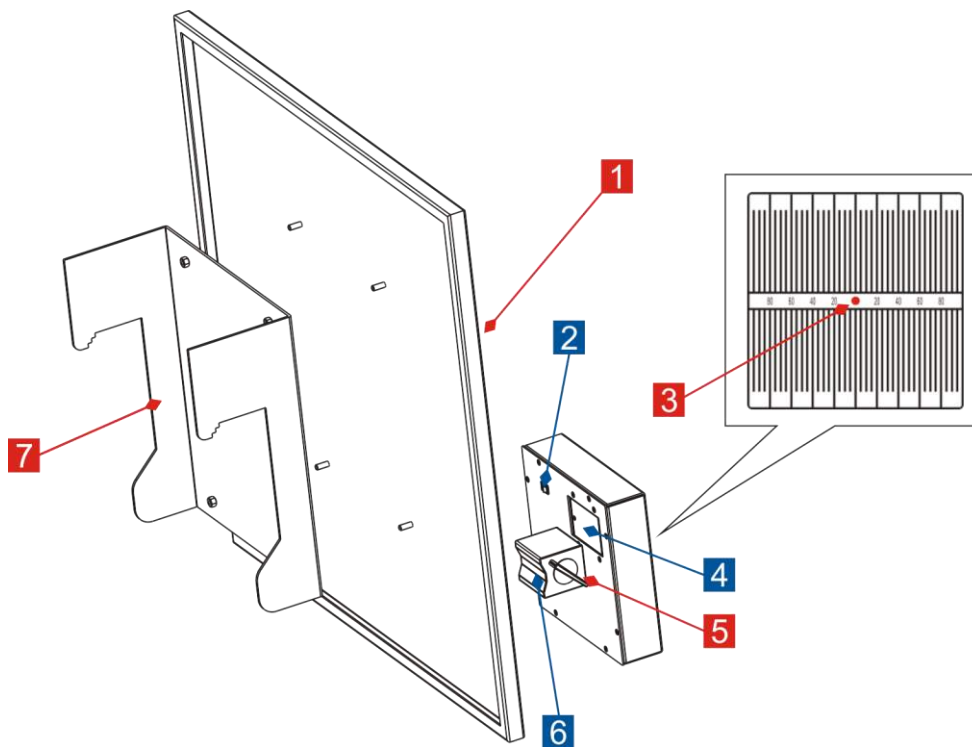

Fig. 3-10

No.	Description
1	Radar Reflector
2	Switch Switch the laser on and off.
3*	Output of laser beam Use the laser beam to read the actual value at the scale of the magnetic laser.
4*	Battery Compartment Cover Insert three AA batteries here.
5*	Tuning Lever (Magnet base) Switch the electromagnet on and off.
6*	Electromagnet

	Switch the electromagnet on so that it can firmly attach on the radar reflector. To detach it, turn the lever off.
7	Attachment Bracket To mount the radar kit on the cross member.

*Note: Items 3~6 are main parts of the magnetic laser.

Replacing the batteries

Proceed as follows to replace the batteries:

1. Switch off the laser beam (3) with the switch (2).
2. Loosen the screw of the battery compartment cover (4), and then push it along the OPEN indicator to remove it.
3. Take out the batteries individually and follow the correct installation direction/battery polarities to install the new batteries.
4. Reassemble it in reverse order.

3.8 Laser Range Finder

3.8.1 Installing the battery

1. Open the battery cover.
2. Put the battery in it correctly.
3. Close the battery cover.

*Note: Please take out the battery if you don't use the meter for a long time.

3.8.2 Operation tips

- **MEAS:** If the meter is OFF, press it to power on meter and laser. Press it again, the measurement begins and the measurement result will be displayed on the screen promptly.
- **CLR:**
 - 1) Long press this button will power off. This meter will automatically power off without operation for 3 minutes.
 - 2) Cancel the last instruction or clear the display.
- It is forbidden to place the meter into water, please use the soft and damp cloth to clean it. Do not use corrosion or volatilization to clean it.

- When measuring no reflected or dark surface, it will increase the measuring time.
- If the surface of the object is liquid or clear transparent substance, it will make mistake.
- If the object has very strong reflected light, the laser may reflected, and it will make error.

4 Initial Use

4.1 Installing the ADAS Calibration Tool

4.1.1 Installing the beam lifter on the base support

Follow the steps mentioned below to proceed:

1. Use the set screws to fix the base support (Rotate the screws until the carrier foot cups firmly stand on the ground) to prevent it from sliding.

Note: The heavy tool may drop down and cause injuries, remember to always install the beam lifter with the aid of a second person or use suitable aid as necessary.

2. Take out the beam lifter from the package box, gently attach it on the base support, with the mounting holes on the beam lifter aligning with ones on the base support. Use the screws to lock it on the base support.

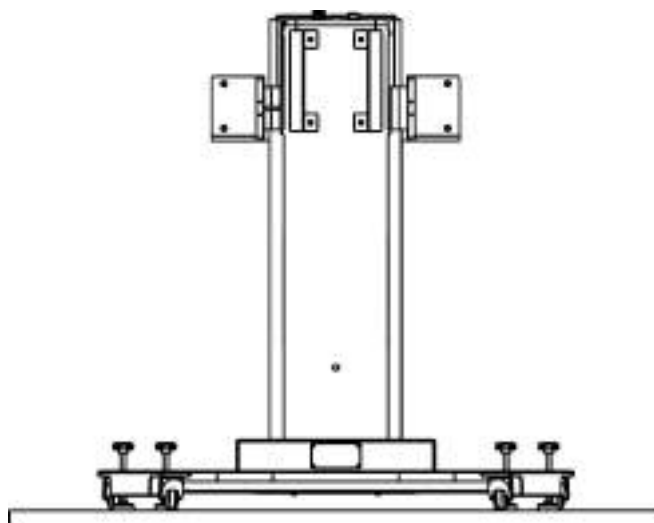

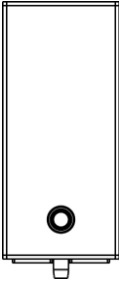
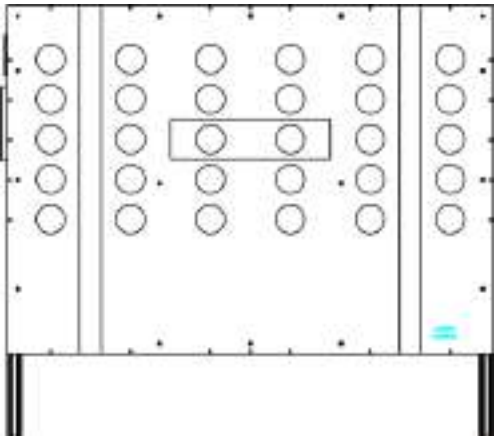

Fig. 4-1

3. Insert one end of the power adaptor into the DC-IN port of the beam lifter, and the other end to the AC outlet.

4.1.2 Installing the cross member & calibration frame

While installing the cross member and calibration frame, please prepare the following items:

Cross member	
Laser modules (x 2)	
Calibration frame	

1. Secure the cross member on the beam lifter: There are two scales (the distance between them indicates the width of cross-linking bracket 2) marked on the cross-member and next to them are 4 floating screws pre-installed in the sliding rail 1 & 4 respectively. See Fig. 4-2.

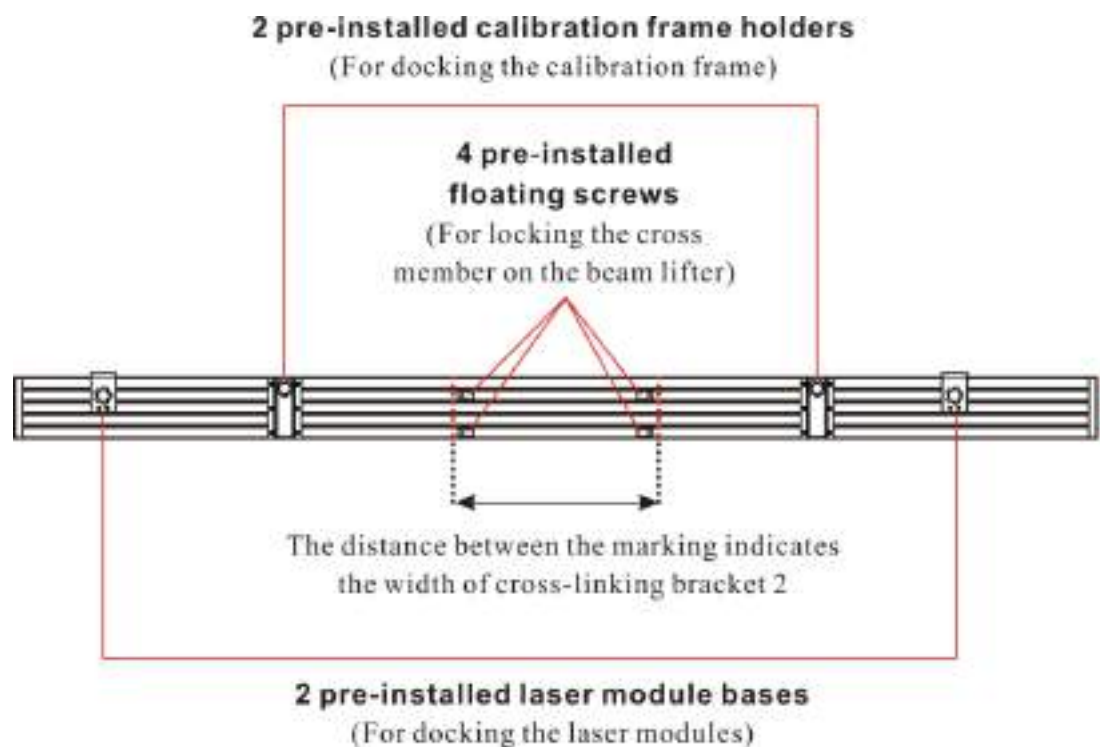

Fig. 4-2

When the cross member is centrally located on the beam lifter, align the mounting holes on the cross-linking bracket 2 with the floating screws on the cross member, and then use the dedicated screws to fasten the cross member on the beam lifter.

*Note: If a thick film is covered on the cross member, please remove it from the cross member when installing.

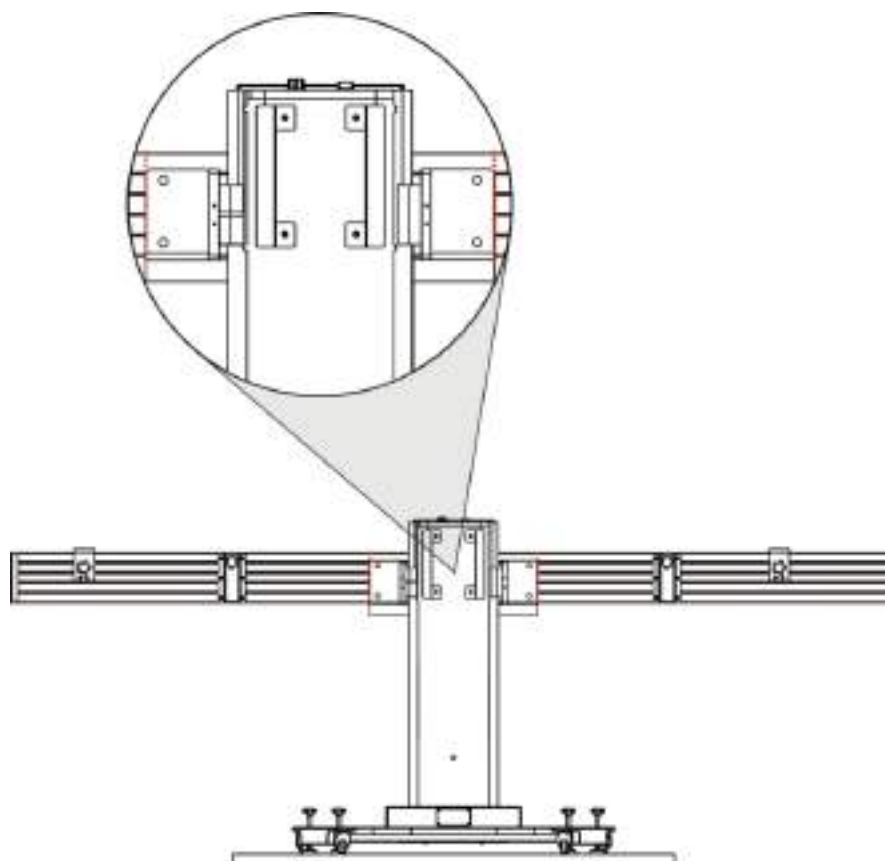

Fig. 4-3

2. Install the calibration frame: Hold the handles to lift the calibration frame up, and insert it into the calibration frame holder at the same time until it reaches to the bottom. See Fig. 4-4. Use the set screws to fix it.

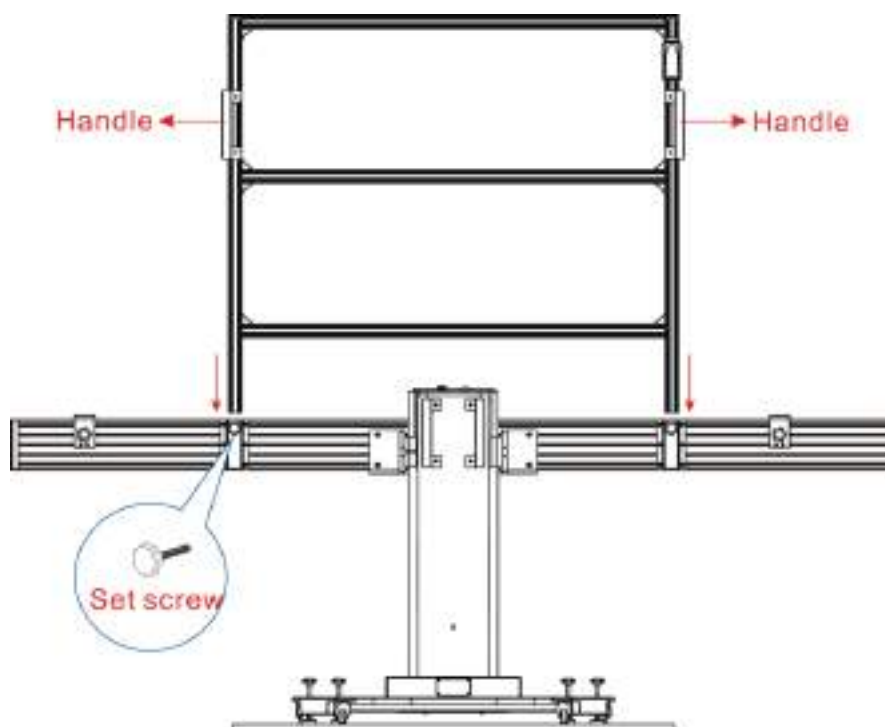

Fig. 4-4a



Fig. 4-4b

*Caution: The calibration frame is heavy and may drop when installing and may cause injuries. You are strongly suggested to ask a second person to install it together.

3. Mount the laser modules on the cross member: Mount the two laser modules on the support base respectively ensuring the output of laser beam aimed at the wheel clamp, and then use the set screws to fasten it.

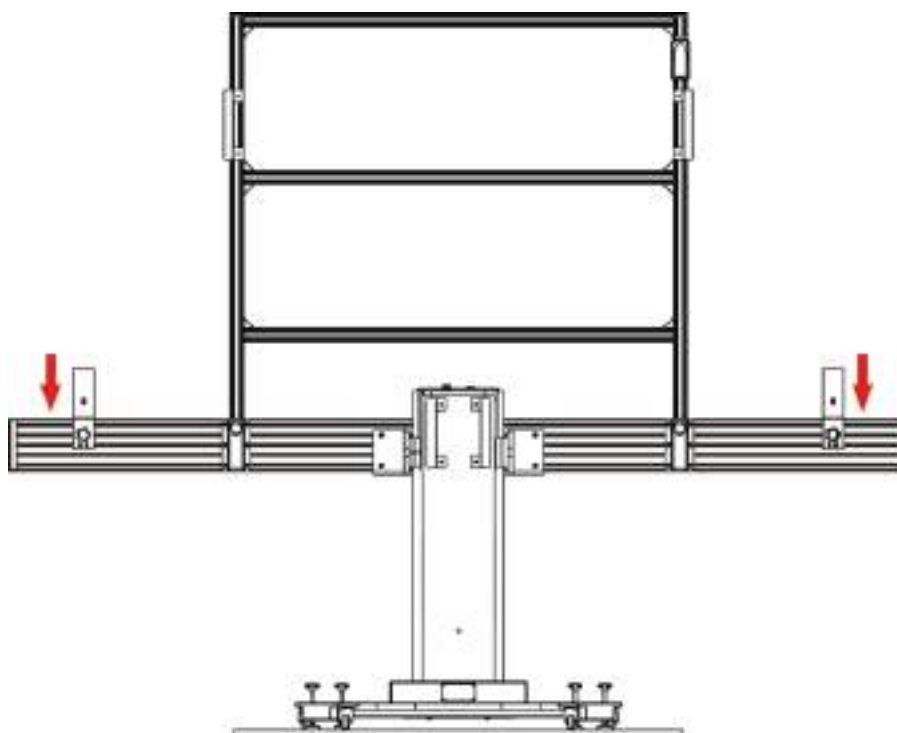

Fig. 4-5

4.1.3 Installing the radar kit

To calibrate the radar-based ADAS system, a radar kit is required.

*Note: While calibrating the front camera, NEVER keep the radar kit hanging on the cross member.

1. Switch off the laser beam (3) with the switch (2).
2. Hang the radar reflector (1) on the center of the cross member until it is firmly attached on the cross member. The radar reflector must be within the radar sensor area.

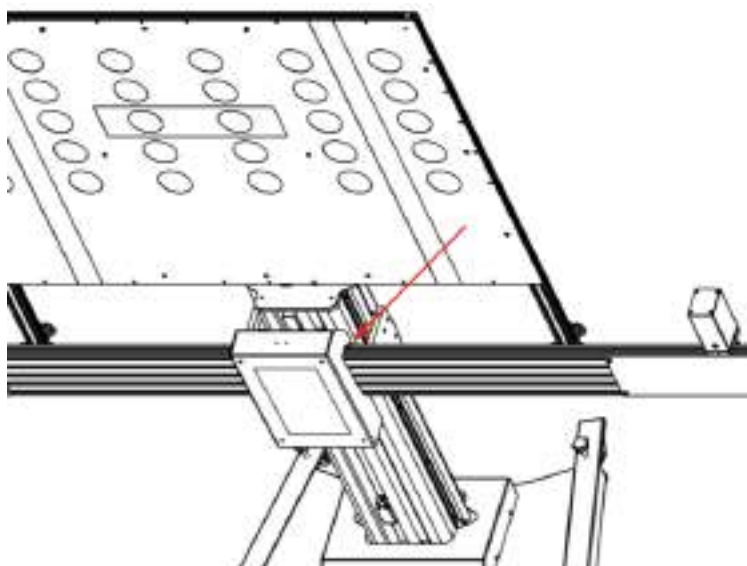

Fig. 4-6

4.1.4 Installing the calibration reference pattern

Before calibrating, you need to install the vehicle-specific calibration pattern. Follow the steps below to proceed.

1. There are two mounting holes on each of calibration panels for front camera. Align the calibration pattern with the top horizontal holes of calibration frame.

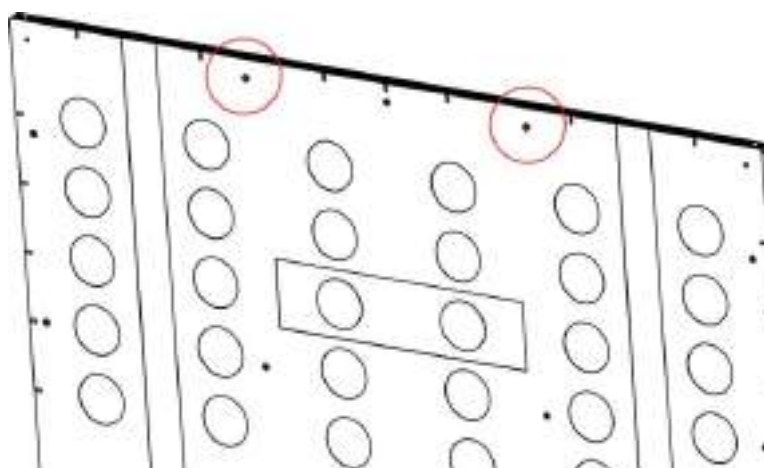

Fig. 4-7

2. Use the screws to fasten it on the calibration panel.

4.2 Activate the Software Calibration Function

By default, the calibration feature of the pre-installed diagnostic software of LAUNCH scanners is disabled. To ensure normal use of the calibration function of the diagnostic software, you need to activate the pin card to unlock the calibration function on the LAUNCH scanner (sold separately) first.

Follow the steps below to activate it. Here we take *X-431 PAD II* for example to demonstrate how to activate the ADAS function.

*Note: Different LAUNCH scanners have different accesses to the ADAS function. For details, please refer to the user manual of individual scanner.

1. Press the [POWER] button on the diagnostic tool to turn it on.
2. Tap the application icon on the home screen to launch it.
3. Log in the system, a screen similar to the following figure appears:



Fig. 4-8

*Note: Alternatively, user also can directly activate ADAS by tapping  -> "Profile" -> "Activate ADAS".

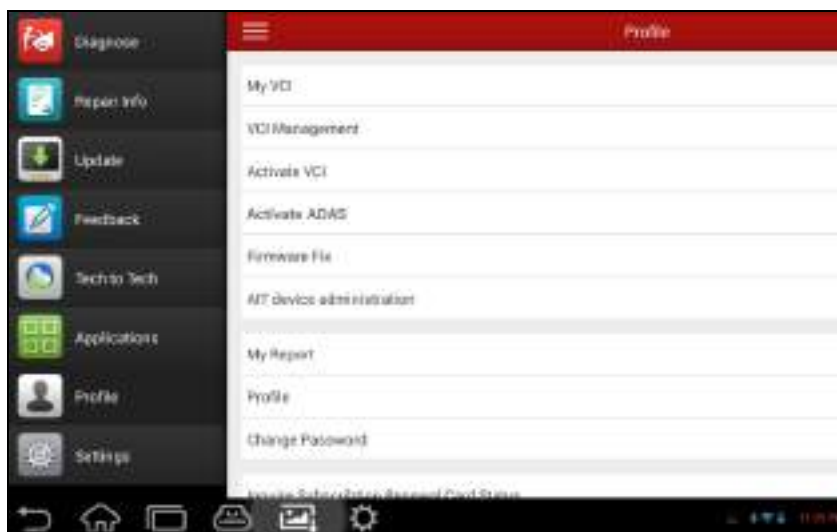

4. Tap "ADAS" under the "Automotive" tab. If the ADAS is not activated, the following prompt window displays.



Fig. 4-9

5. Tap “Activate” to enter the ADAS activation screen.

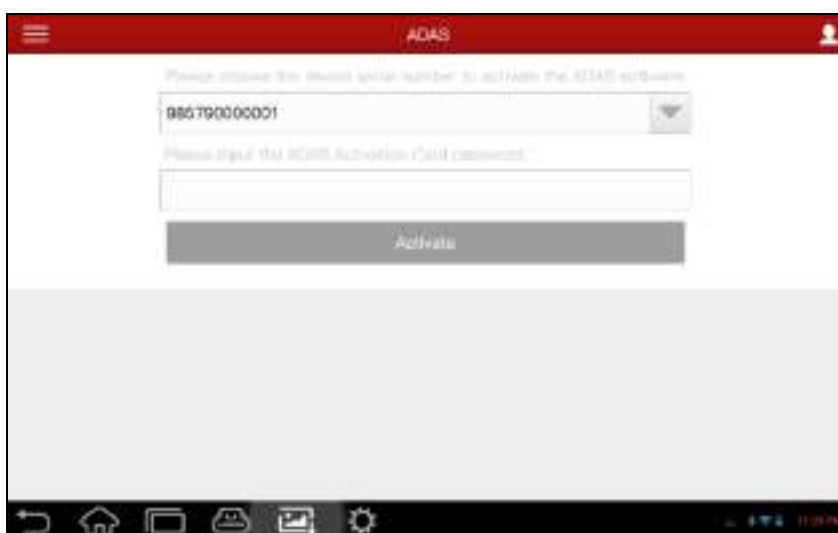

Fig. 4-10

6. Scratch or scrap the designated area on the included Activation Card to reveal the password, and input the 24-digit password to activate it.

7. Now the ADAS function becomes accessible and is ready for use.

5 Working with the ADAS Calibration Tool

The calibration operation should be performed strictly following the on-screen instructions on the diagnostic tool. For some vehicle models, calibration pattern and calibration tool are not mandatory. But for some camera-based ADAS, the calibration can not be done without the help of calibration tool and calibration pattern. In this case, for the positioning of the calibration tool and vehicle, it is necessary for the user to manually finish it.

The following steps are necessary to work with the ADAS Calibration System:

1. Place the ADAS calibration panel in front of (for front camera)/behind (for rear camera) the vehicle (Refer to Chapter 5.2.1.1/Chapter 5.2.2.1 respectively).
2. Place the ADAS calibration panel centred in front of (for front camera)/behind (for rear camera) the vehicle (Refer to Chapter 5.2.1.2/Chapter 5.2.2.2 respectively).
3. Place the ADAS calibration panel in parallel with the vehicle (Refer to Chapter 5.2.1.3/Chapter 5.2.2.3 respectively).
4. Adjust the height of the calibration panel (See Chapter 5.2.1.4).

5.1 Precondition for the Use of the ADAS Calibration Tool

Regard the following in order to use the ADAS calibration tool:

- Vehicle system is working properly.
- No trouble codes stored in ECU memories.
- Prepare vehicle-specific calibration reference pattern.
- A LAUNCH's scanner supporting ADAS system calibrating is required (sold separately).
- Front & rear axle track is properly adjusted.
- To make you work smoothly and calibrate accurately, please make sure the following conditions are met:

1. Workstation size

Distance A = about 2.8m (the width of the cross member)

Distance B = about 1m (from the cross member to the wall)

Distance C = at least 0.5m (from the edge of the cross member to other obstacles)

Distance D = varies from vehicle to vehicle, about 1.5m is strongly recommended (from the calibration panel to the vehicle)

Distance E = reserved for about 1m (from the calibration panel to other obstacles)

Distance F = at least 0.5m (a lane for technician to walk through)

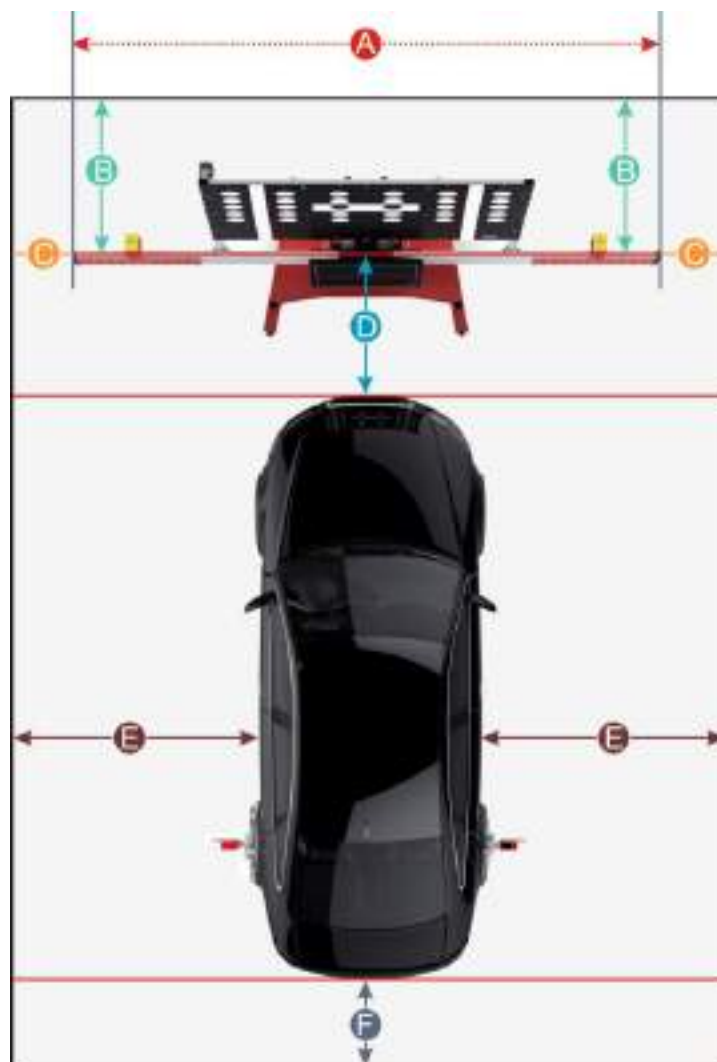



2. Workstation ground

Make sure the vehicle is parked with all wheels on an even floor surface.

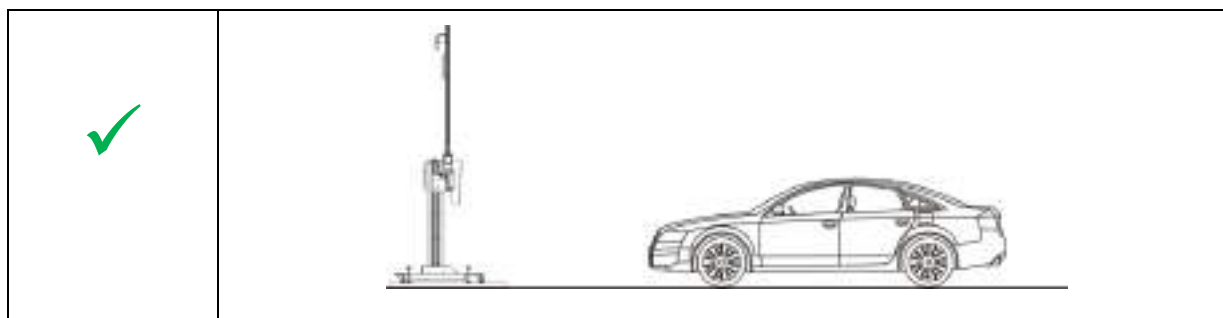
Correct:

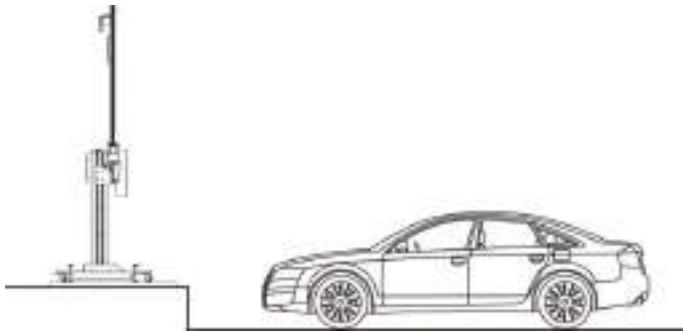
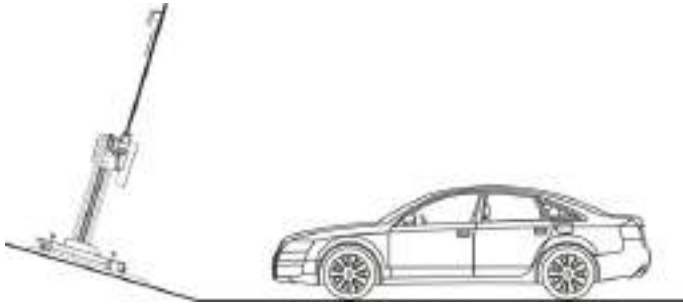

Wrong:

✘	
✘	
✘	

3. Lighting system:

- ✓ The lighting system around the calibration workstation should be a non-frequency flash source, including but not limited to: LED light source, industrial lighting complying with international standards, dual light source in opposite phase.
- ✓ In the field of view of the camera, there should be no direct light source into the camera, otherwise the camera will reduce the exposure so that the captured calibration pattern becomes darker, adversely affecting the calibration.
- ✓ The light source should ensure that there is no reflected spot on the calibration panel.
- ✓ The light source should ensure uniform illumination distribution in the calibration workstation.
- ✓ The brightness of the light should not be changed, and ensure that there will be no other changing light source around the workstation, such as a driving vehicle with lights ON, etc.

5.2 Calibrating Camera-based ADAS

5.2.1 Calibrating the front camera

Generally, you have to go through the following steps to calibrate the vehicle's front camera.

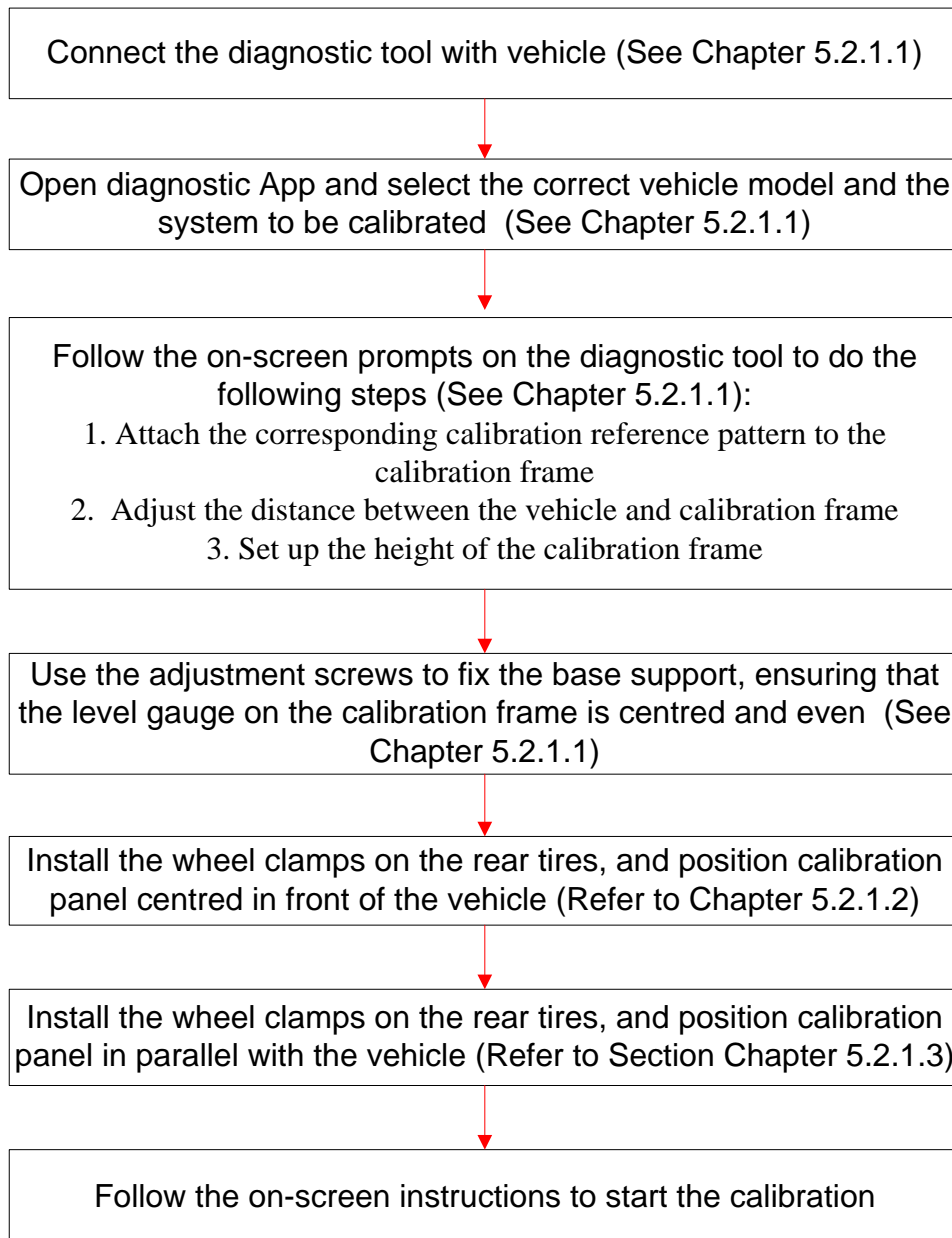

5.2.1.1 Placing the ADAS calibration panel in front of the vehicle

Proceed as follows to place the ADAS calibration panel in front of the vehicle:

1. Connect the diagnostic tool to the vehicle.
 - 1). Locate the vehicle's DLC (Data Link Connector).

The DLC (Data Link Connector or Diagnostic Link Connector) is typically a standard 16-pin connector where diagnostic code readers interface with the vehicle's on-board computer. The DLC is usually located 12 inches from the center of the instrument panel (dash), under or around the driver's side for most vehicles. If DLC is not located under dashboard, a label should be there telling location. For some Asian and European vehicles, the DLC is located behind the ashtray and the ashtray must be removed to access the connector. If the DLC cannot be found, refer to the vehicle's service manual for the location. See Fig. 5-1 for DLC location.

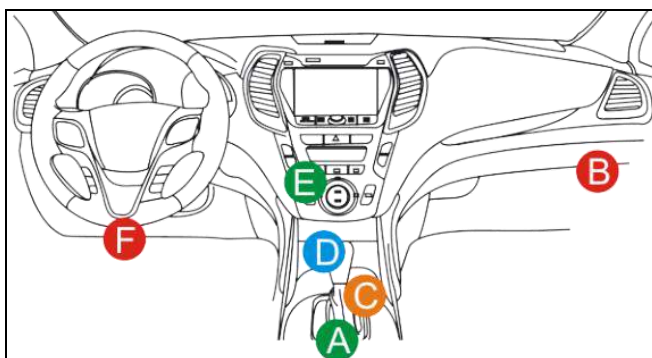

Fig. 5-1

- 2). Plug the VCI device into the vehicle's DLC socket. The power LED of the VCI device illuminates solid red.
- 3). Turn the diagnostic tool on and enter the home screen.
- 4). Bluetooth setup: Enter Bluetooth setting screen by tapping "Settings" -> "Bluetooth", slide the Bluetooth switch to ON and the handset starts searching for all available Bluetooth device. Tap the desired VCI device to pair and match. By default, the Bluetooth ID of the connector is 9*****00 (where ***** stands for 9 digits). If the Bluetooth pair request pops up on the screen, enter the request pin code (default code: 0000 or 1234). Once the VCI is paired with the diagnostic tool, it will be shown under the paired device tab.

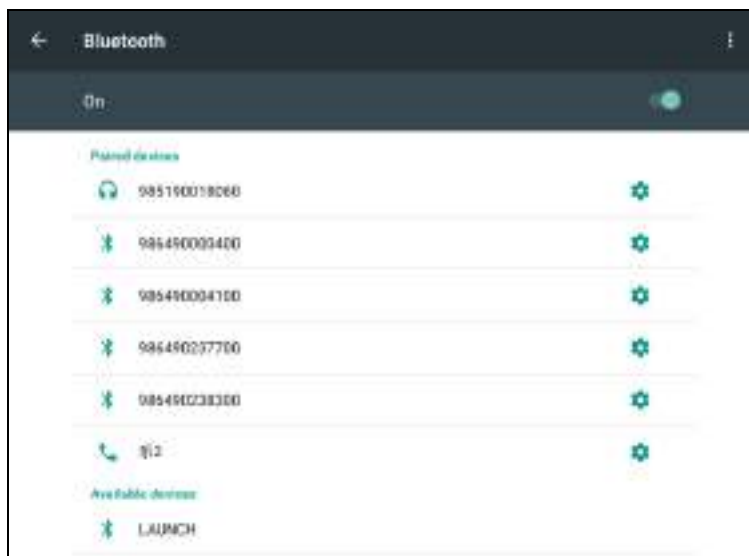

Fig. 5-2

2. Launch the diagnostic/ADAS App.
3. Follow the on-screen instructions to select the identified vehicle model and the system to be calibrated, e.g. MFK.
4. A window with information and instructions appears.

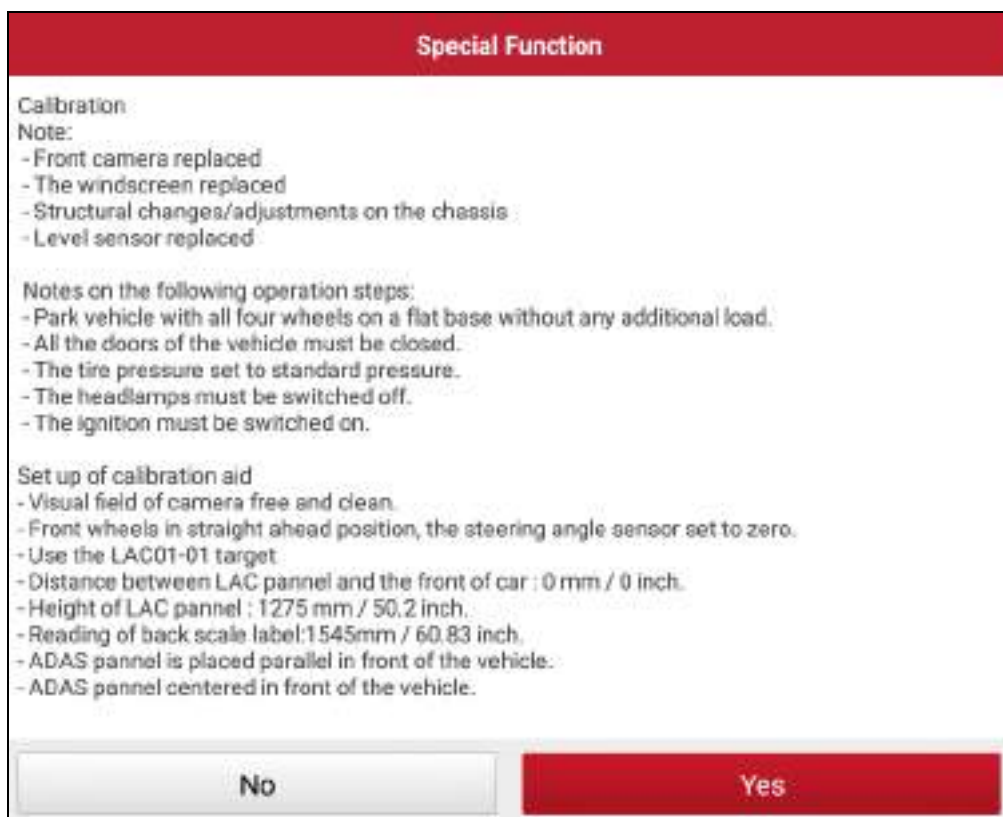

Fig. 5-3 (The screenshot varies from vehicle to vehicle.)

A. Attach the calibration reference pattern to the calibration frame: According to the

prompt message in Fig. 5-3, choose the corresponding calibration reference pattern and attach it to the calibration panel (Refer to Chapter 4.1.5).

B. To adjust the distance between the calibration panel and the vehicle: follow the instructions on the screen to proceed, if necessary, use the laser range finder (included in the packing list) to measure from the vehicle to the calibration panel.

C. To set up the height of the calibration frame: Place the laser range finder in position and keep the screen facing down. Use the Rocker switch on the beam lifter to move the calibration panel up to the height indicated in the diagnostic tool (Fig. 5-3).

5. Use the adjusting screws of the base support to adjust so that the horizontal and the vertical level gauge of the calibration frame are centred respectively.

Now the calibration panel is placed correctly in front of the vehicle.

5.2.1.2 Placing the ADAS calibration panel centred in front of the vehicle

In this step, we just need to make sure that the left (CL) and right (CR) scale of the cross member projected from the wheel clamp laser show the same values.



Fig. 5-4

Proceed as follows to place the ADAS calibration panel centred in front of the vehicle:

1. Attach one wheel clamp on the left rear wheel.

***Note: You are strongly recommended to install the wheel clamp on the rear wheel since the farther distance (between the calibration panel and wheel clamp) makes the calibration more accurate.**

2. Align the scales of the wheel clamp at a right angle. Ensure that the level gauge bubbles of both wheel clamps are centred.

3. Switch on the laser beam of the laser module with the switch.

***Caution: Laser radiation may cause damage to/destruction of the retina. Never look directly into the laser beam.**

4. Align the laser module by setting a desired height on the scale of the cross member.

***Tips: If the laser beam of the wheel clamp positions at a greater value on the cross member, slightly push the calibration frame rightwards.**



Fig. 5-5

5. Perform steps 3-4 for the second laser module of wheel clamp.

6. By moving the calibration frame laterally, place the panel in a way that the left and right scale of the cross member projected from the wheel clamp laser show the same values.

Now the calibration panel is placed centred in front of the vehicle.



Fig. 5-6

5.2.1.3 Placing the ADAS calibration panel in parallel with the vehicle

In this step, we just need to make sure that the left (WL) and right (WR) scale of the wheel clamp reflected from the laser modules on the cross member show the same values.



Fig. 5-7

Proceed as follows to place the ADAS calibration panel in parallel with the vehicle:

1. Switch on the laser beam of the laser module with the switch.
2. Align the laser beam of the laser module on the cross member with the scale of the wheel clamp. The laser beam will be projected onto the scale of the wheel clamp.
3. Perform step 1-2 with the second laser beam.
4. **By axially turning the calibration frame, place the frame in a way that the left and right scale of the wheel clamp reflected from the laser modules on the cross member show the same values.**



Fig. 5-8

Now the calibration panel is placed in parallel with the vehicle.

5.2.2 Calibrating the rear camera

5.2.2.1 Placing the ADAS calibration panel behind the Vehicle

Proceed as follows to place the ADAS calibration panel behind the vehicle:

1. Connect the diagnostic tool to the vehicle.
2. Launch the diagnostic/ADAS App.
3. Follow the on-screen instructions to select the identified vehicle model and the system to be calibrated, e.g. MFK.
4. A window with information and instructions appears.
 - A. Attach the calibration reference pattern to the calibration frame: According to the prompt message, choose the corresponding calibration reference pattern and attach it to the calibration panel (Refer to Chapter 4.1.5).
 - B. To adjust the distance between the calibration panel and the vehicle: follow the instructions on the screen to proceed, if necessary, use the laser range finder (included in the packing list) to measure from the vehicle to the calibration panel.
 - C. To set up the height of the calibration frame: Place the laser range finder in position and keep the screen facing down. Use the Rocker switch on the beam lifter to move the calibration panel up to the height indicated in the diagnostic tool (Fig. 5-3).
5. Use the adjusting screws of the base support to adjust so that the horizontal and the vertical level gauge of the calibration frame are centred respectively. Now the calibration panel is placed correctly in rear of the vehicle.

5.2.2.2 Placing the ADAS calibration panel centred in rear of the Vehicle

Proceed as follows to place the ADAS calibration panel centred behind the vehicle:

1. Attach one wheel clamp on the left front wheel.

***Note: You are strongly recommended to install the wheel clamp on the front wheel since the farther distance (between the calibration panel and wheel clamp) makes the calibration more accurate.**

2. Align the scales of the wheel clamp at a right angle.

***Note:** Ensure that the level gauge bubbles of both wheel clamps are centred.

3. Switch on the laser beam of the laser module with the switch.

***Caution:** Laser radiation may cause damage to/destruction of the retina. Never look directly into the laser beam.

4. Align the laser module by setting a desired height on the scale of the cross member.

5. Perform steps 3-4 for the second laser module of wheel clamp.

6. By moving the calibration frame laterally, place the frame in a way that the left and right scale of the cross member projected from the wheel clamp laser show the same values.

Now the ADAS calibration panel is placed centred in rear of the vehicle.

5.2.2.3 Placing the ADAS calibration panel in parallel with the vehicle

Proceed as follows to place the ADAS calibration panel in parallel with the vehicle:

1. Switch on the laser beam of the laser module with the switch.

2. Align the laser beam of the laser module on the cross member with the scale of the wheel clamp. The laser beam will be projected onto the scale of the wheel clamp.

3. Perform step 1-2 with the second laser beam.

4. By axially turning the calibration frame, place the frame in a way that the left and right scale of the wheel clamp reflected from the laser modules on the cross member show the same values.

Now the ADAS calibration panel is placed in parallel with the vehicle.

5.2.2.4 Placing the ADAS calibration panel of rear camera behind the vehicle

1. After properly placing the ADAS calibration frame, follow the instructions on diagnostic tool to proceed.

2. Remove the calibration frame and place the calibration panel of rear camera on the floor, and then move it in a right position behind the vehicle according to the plumb

line.

3. Start the calibration following the on-screen instructions on the diagnostic tool.

5.3 Calibrating Radar-based ADAS

X-431 ADAS PRO calibration system provides a Radar expansion kit for the calibration of the radar-based Advanced Driver Assist Systems (ADAS). Compatible with the systems used by VAG and on certain ADAS-equipped Mercedes-Benz models, it extends the capability of the X-431 ADAS PRO calibration tool beyond just camera-based systems.

Before proceeding this step, please make sure the following conditions must be met:

- Place the X-431 ADAS PRO calibration panel in front of the vehicle.
- Ensure the vehicle is stopped on even surface.
- Level gauge bubble of radar reflector is centred.
- Prepare the radar kit.



Fig. 5-9 (Magnetic laser)



Fig. 5-10 (Radar reflector, also called reflector mirror)

Depending on vehicle manufacturer, model and year of manufacture, the radar sensor can be calibrated directly (without magnetic laser) or must be calibrated with the magnetic laser.

5.3.1 Calibrating the radar sensor with magnetic laser

Proceed as follows to calibrate the radar sensor with the magnetic laser:

1. Connect the diagnostic tool to the vehicle.
2. Launch the diagnostic App and select “Local Diagnosis” on the Job menu.
3. Follow the on-screen instructions to select the identified vehicle model and the system to be calibrated.

A window with information and instructions appears.

*Caution: The radar reflector may drop when attaching it to the cross member and may cause injuries. You are strongly suggested to ask a second person to attach the radar reflector to the cross member.

4. Refer to Chapter 4.1.3 to attach the radar reflector to the cross member.
5. Turn the tuning lever at the magnet base of the magnetic laser to ON. The electromagnet becomes activated and the magnetic laser can be fixed onto the radar reflector.
6. Switch on the laser beam with the switch of the magnetic laser.

*Caution: Laser radiation may cause damage to/destruction of the retina. Never look directly into the laser beam.

7. Fix the magnetic laser onto the radar reflector. Make sure that the radar reflector must be within the radar sensor area.
8. Direct the laser beam at the magnetic laser centred to the mirror of the radar sensor. The laser beam will be reflected from the mirror to the scale of the magnetic laser.
9. Shift the magnetic laser slowly so that the horizontal and vertical level gauge bubbles are centred.
10. Observe the on-screen prompt information and instructions to calibrate the radar sensor.
11. After calibrating the radar sensor, switch off the laser beam on the magnetic laser.

5.3.2 Calibrating the radar sensor without magnetic laser

Proceed as follows to calibrate the radar sensor without the magnetic laser:

1. Connect the diagnostic tool to the vehicle.
2. Launch the diagnostic App and select “Local Diagnosis” on the Job menu.
3. Follow the on-screen instructions to select the identified vehicle model and the system to be calibrated.

A window with information and instructions appears.

*Caution: The radar reflector may drop when attaching it to the cross member and may cause injuries. You are strongly suggested to ask a second person to attach the reflector to the cross member.

4. Refer to Chapter 4.1.3 to attach the radar reflector to the cross member. The radar reflector must be within the radar sensor area.
5. Follow the instructions on the screen to calibrate the radar sensor.

6 Care & Maintenance



- For every spare part, the ADAS calibration tool should also be handled with care.
- Regularly lubricate moving parts with acid-free and resin-free grease or oil.
- Clean the ADAS calibration tool with non-aggressive cleaning agents on a regular basis.
- Use commercial household cleaning detergents and a moistened, soft cleaning cloth.
- Always use original spare parts to replace damaged accessories immediately.

Appendix: Car ADAS Reference Pattern Kit

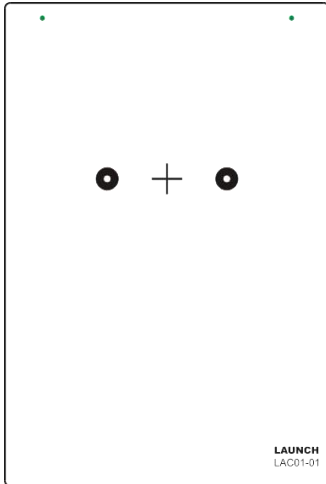
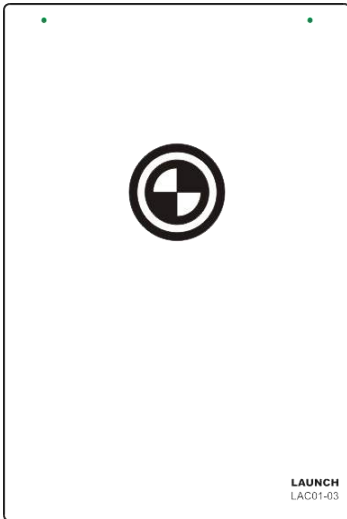
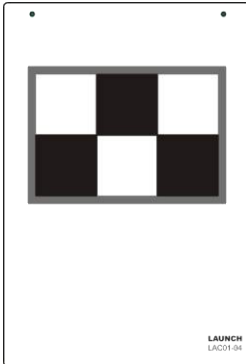

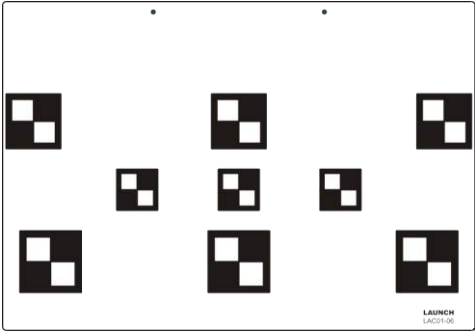
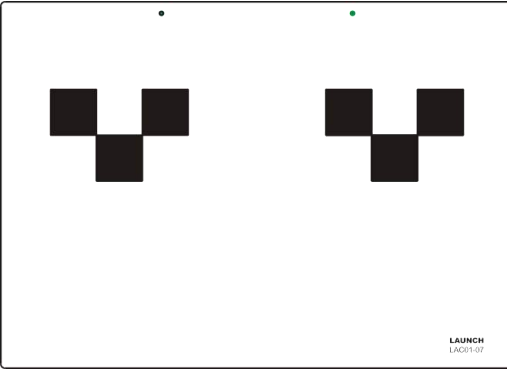
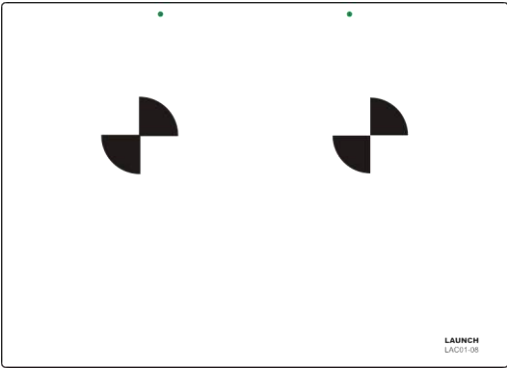

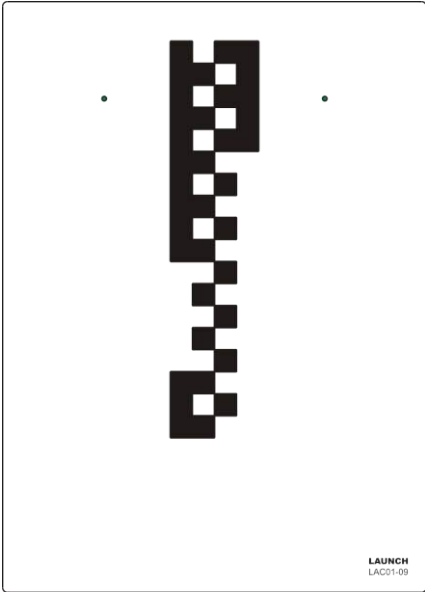
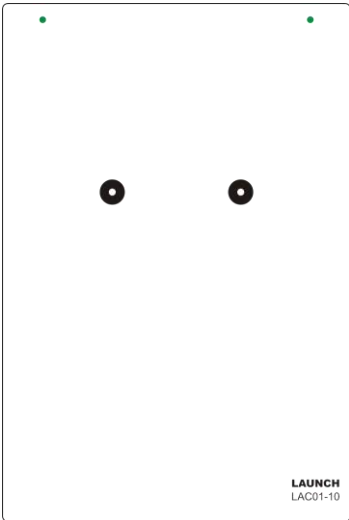
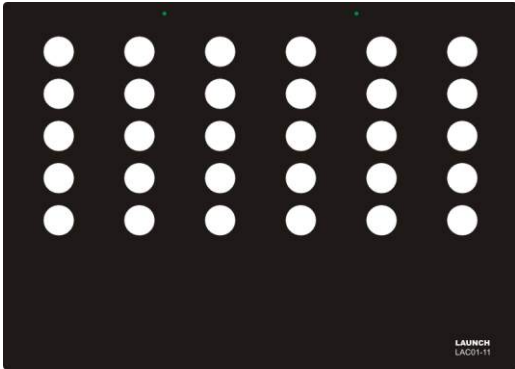
1. Front Camera Panels Kit Configuration (301250002)

No.	Panel Name	Panel Code	Pattern	Qt.
1	MERCEDES-FC (301250005)	LAC01-01		1
2	HONDA-FC 01 (301250007)	LAC01-03		1
3	HONDA-FC 02 (301250008)	LAC01-04-L LAC01-04-R		2



<p>4</p>	<p>TOYOTA-FC (301250009)</p>	<p>LAC01-06</p>		<p>1</p>
<p>5</p>	<p>NISSAN-FC 01 (301250010)</p>	<p>LAC01-07</p>		<p>1</p>
<p>6</p>	<p>NISSAN-FC 02 (301250011)</p>	<p>LAC01-08</p>		<p>1</p>

<p>7</p>	<p>HYUNDAI/KIA-F C (301250012)</p>	<p>LAC01-09</p>		<p>1</p>
<p>8</p>	<p>MAZDA-FC 01 (301250013)</p>	<p>LAC01-10</p>		<p>1</p>
<p>9</p>	<p>ALFA GIULIA-FC (301250014)</p>	<p>LAC01-11</p>		<p>1</p>
<p>10</p>	<p>MAZDA-FC 02 (301250019)</p>	<p>LAC01-16</p>		<p>1</p>







2. Rear Camera & AVM Panels configuration(Asian) (301250023)

No.	Panel Name	Panel Code	Pattern	Qt.
1	HONDA-AVM	LAC04-01		4
		LAC04-02		1
2	NISSAN-AVM	LAC04-11		1
3	HYUNDAI-AVM	LAC04-12-01		1
		LAC04-12-02		1

3. Rear Camera & AVM Panels configuration(American) (301250024)

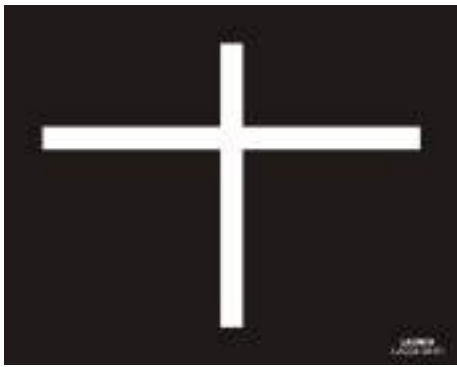
No.	Panel Name	Panel Code	Pattern	Qt.
1	CADILAC -AVM	LAC04-06		1
2	FORD -AVM	LAC04-07		2

4. Rear Camera & AVM Panels configuration(European) (301250025)

No.	Panel Name	Panel Code	Pattern	Qt.
1	MERCEDES-RC	LAC02-02		1
2	VW-RC	LAC02-03		1
3	VW-AVM	LAC04-04		2
4	MERCEDES-RF K	LAC04-08-01		1
		LAC04-08-02		1
5	RENAULT-AVM	LAC04-10-01		1
		LAC04-10-02		1

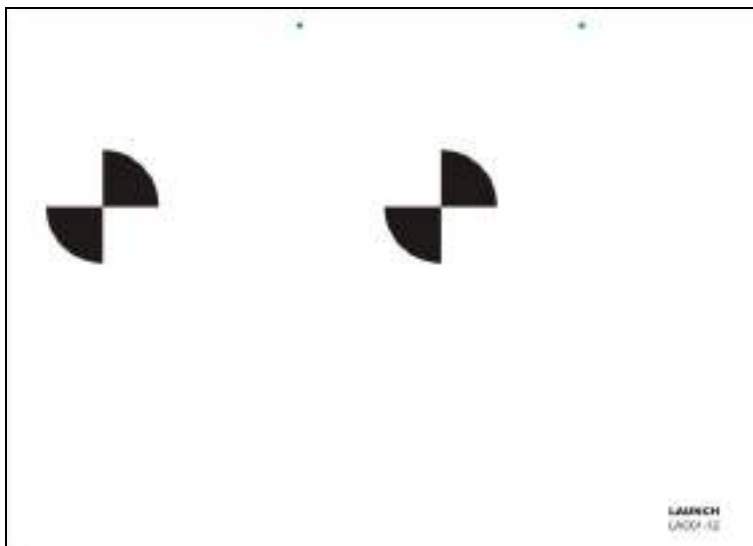
5. Corner Radar Reflector configuration (301250022)**6. RENAULT/SMART Front Camera single target configuration(LAC01-12) (301250015)****7. DAIHATSU Front Camera single target configuration(LAC01-14) (301250017)**

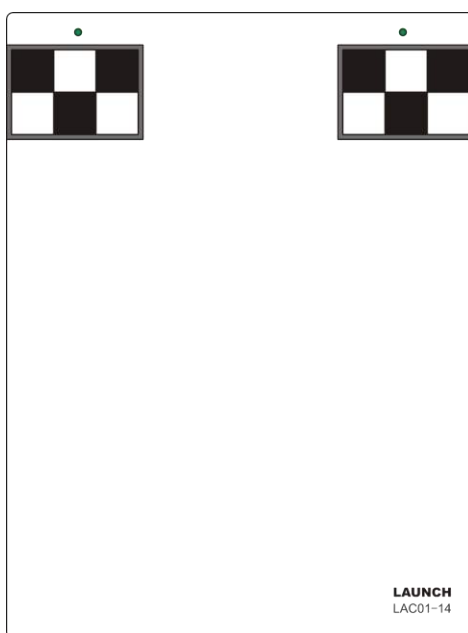

8. SUBARU Front Camera single target configuration(LAC01-15) (301250018)

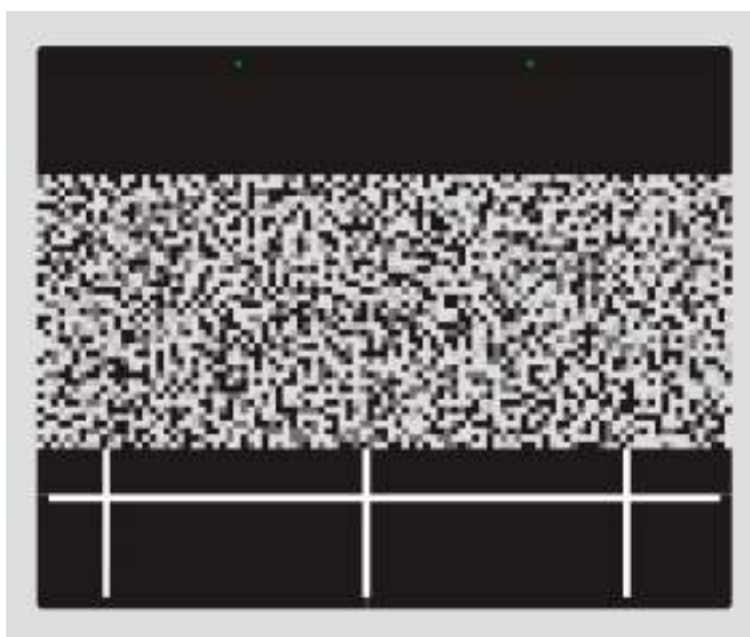

9. HONDA Front Camera single target configuration 3(LAC01-17) (301250020)



Warranty

THIS WARRANTY IS EXPRESSLY LIMITED TO PERSONS WHO PURCHASE LAUNCH PRODUCTS FOR PURPOSES OF RESALE OR USE IN THE ORDINARY COURSE OF THE BUYER'S BUSINESS.

LAUNCH electronic product is warranted against defects in materials and workmanship for one year from date of delivery to the user.

This warranty does not cover any part that has been abused, altered, used for a purpose other than for which it was intended, or used in a manner inconsistent with instructions regarding use. The exclusive remedy for any automotive meter found to be defective is repair or replacement, and LAUNCH shall not be liable for any consequential or incidental damages.

Final determination of defects shall be made by LAUNCH in accordance with procedures established by LAUNCH. No agent, employee, or representative of LAUNCH has any authority to bind LAUNCH to any affirmation, representation, or warranty concerning LAUNCH automotive meters, except as stated herein.

Disclaimer

The above warranty is in lieu of any other warranty, expressed or implied, including any warranty of merchantability or fitness for a particular purpose.

Purchase Order

Replaceable and optional parts can be ordered directly from your LAUNCH authorized tool supplier. Your order should include the following information:

Order quantity

Part number

Part name

THANK YOU FOR CHOOSING LAUNCH!

If you have any questions or comments please contact:

LAUNCH Tech USA (North America)

Website: www.launchtechusa.com

Product Support

Phone: 877-528-6249 xt: 4

Fax: 562-463-1590

Address: 1820 S. Milliken Ave. Ontario, CA 91761

Monday - Friday 5 am - 5 pm PST

Service & Repair

Phone: 877-528-6249 xt: 5
Monday - Friday 8 am - 5 pm PST
Please visit our public form @
<http://launch.activeboard.com>

LAUNCH Europe GmbH (Europe)

Phone: +49 (0) 2273 / 98 75 55
Email: service@launch-europe.de
Address: Heinrich-Hertz-Str. 10, D-50170 Kerpen

LAUNCH TECH. CO., LTD. (Other Areas)

Website: www.x431.com
www.cnlaunch.com
Phone: +86 755 8455 7891
Email: overseas.service@cnlaunch.com
Address: Customer Service Department
LAUNCH TECH. CO., LTD.
Launch Industrial Park,
North of Wuhe Avenue,
Banxuegang, Bantian,
Longgang, Shenzhen, Guangdong
P.R.China, 518129

Statement:

LAUNCH reserves the rights to make any change to product designs and specifications without notice. The actual object may differ a little from the descriptions in the manual in physical appearance, color and configuration. We have tried our best to make the descriptions and illustrations in the manual as accurate as possible, and defects are inevitable, if you have any question, please contact local dealer or after-sale service center of LAUNCH, LAUNCH does not bear any responsibility arising from misunderstandings.